

Notice for TAIYO YUDEN Products

Please read this notice before using the TAIYO YUDEN products.

⚠ REMINDERS

Product Information in this Catalog

Product information in this catalog is as of March 2023. All of the contents specified herein and production status of the products listed in this catalog are subject to change without notice due to technical improvement of our products, etc. Therefore, please check for the latest information carefully before practical application or use of our products.

Please note that TAIYO YUDEN shall not be in any way responsible for any damages and defects in products or equipment incorporating our products, which are caused under the conditions other than those specified in this catalog or individual product specification sheets.

Approval of Product Specifications

Please contact TAIYO YUDEN for further details of product specifications as the individual product specification sheets are available. When using our products, please be sure to approve our product specifications or make a written agreement on the product specification with TAIYO YUDEN in advance.

Pre-Evaluation in the Actual Equipment and Conditions

Please conduct validation and verification of our products in actual conditions of mounting and operating environment before using our products.

Limited Application

1. Equipment Intended for Use

The products listed in this catalog are intended for general-purpose and standard use in general electronic equipment for consumer (e.g., AV equipment, OA equipment, home electric appliances, office equipment, information and communication equipment including, without limitation, mobile phone, and PC) and other equipment specified in this catalog or the individual product specification sheets, or the equipment approved separately by TAIYO YUDEN.

TAIYO YUDEN has the product series intended for use in the following equipment. Therefore, when using our products for these equipment, please check available applications specified in this catalog or the individual product specification sheets and use the corresponding products.

Application	Product Series		Quality Grade ^{*3}
	Equipment ^{*1}	Category (Part Number Code ^{*2})	
Automotive	Automotive Electronic Equipment (POWERTRAIN, SAFETY)	A	1
	Automotive Electronic Equipment (BODY & CHASSIS, INFOTAINMENT)	C	2
Industrial	Telecommunications Infrastructure and Industrial Equipment	B	2
Medical	Medical Devices classified as GHTF Class C (Japan Class III)	M	2
	Medical Devices classified as GHTF Classes A or B (Japan Classes I or II)	L	3
Consumer	General Electronic Equipment	S	3
	Only for Mobile Devices ^{*4}	E	4

*Notes: 1. Based on the general specifications required for electronic components for such equipment, which are recognized by TAIYO YUDEN, the use of each product series for the equipment is recommended. Please be sure to contact TAIYO YUDEN before using our products for equipment other than those covered by the product series.

2. On each of our part number, the 2nd code from the left is a code indicating the "Category" as shown in the above table. For details, please check the explanatory materials regarding the part numbering system of each of our products.

3. Each product series is assigned a "Quality Grade" from 1 to 4 in order of higher quality. Please do not incorporate a product into any equipment with a higher Quality Grade than the Quality Grade of such product without the prior written consent of TAIYO YUDEN.

4. The applications covered by this product series are limited to mobile devices (smartphone, tablet PC, smartwatch, handheld game console, etc.) among general electronic equipment for consumer. The design, specifications and operating environment, etc. differ from those of the product series for "General Electronic Equipment" (Category: S), so please check the individual product specification sheets for details. The product series for "General Electronic Equipment" (Category: S) can also be used for mobile devices.

▶ This catalog contains the typical specification only due to the limitation of space. When you consider the purchase of our products, please check our product specification sheets. For details of each product (characteristics graph, reliability information, precautions for use, and so on), see our website (<http://www.ty-top.com/>).

2. Equipment Requiring Inquiry

Please be sure to contact TAIYO YUDEN for further information before using the products listed in this catalog for the following equipment (excluding intended equipment as specified in this catalog or the individual product specification sheets) which may cause loss of human life, bodily injury, serious property damage and/or serious public impact due to a failure or defect of the products and/or malfunction attributed thereto.

- (1) Transportation equipment (automotive powertrain control system, train control system, and ship control system, etc.)
- (2) Traffic signal equipment
- (3) Disaster prevention equipment, crime prevention equipment
- (4) Medical devices classified as GHTF Class C (Japan Class III)
- (5) Highly public information network equipment, data-processing equipment (telephone exchange, and base station, etc.)
- (6) Any other equipment requiring high levels of quality and/or reliability equal to the equipment listed above

3. Equipment Prohibited for Use

Please do not incorporate our products into the following equipment requiring extremely high levels of safety and/or reliability.

- (1) Aerospace equipment (artificial satellite, rocket, etc.)
- (2) Aviation equipment *1
- (3) Medical devices classified as GHTF Class D (Japan Class IV), implantable medical devices *2
- (4) Power generation control equipment (nuclear power, hydroelectric power, thermal power plant control system, etc.)
- (5) Undersea equipment (submarine repeating equipment, etc.)
- (6) Military equipment
- (7) Any other equipment requiring extremely high levels of safety and/or reliability equal to the equipment listed above

*Notes: 1. There is a possibility that our products can be used only for aviation equipment that does not directly affect the safe operation of aircraft (e.g., in-flight entertainment, cabin light, electric seat, cooking equipment) if such use meets requirements specified separately by TAIYO YUDEN. Please be sure to contact TAIYO YUDEN for further information before using our products for such aviation equipment.

2. Implantable medical devices contain not only internal unit which is implanted in a body, but also external unit which is connected to the internal unit.

4. Limitation of Liability

Please note that unless you obtain prior written consent of TAIYO YUDEN, TAIYO YUDEN shall not be in any way responsible for any damages incurred by you or third parties arising from use of the products listed in this catalog for any equipment that is not intended for use by TAIYO YUDEN, or any equipment requiring inquiry to TAIYO YUDEN or prohibited for use by TAIYO YUDEN as described above.

■ Safety Design

When using our products for high safety and/or reliability-required equipment or circuits, please fully perform safety and/or reliability evaluation. In addition, please install (i) systems equipped with a protection circuit and a protection device and/or (ii) systems equipped with a redundant circuit or other system to prevent an unsafe status in the event of a single fault for a failsafe design to ensure safety.

■ Intellectual Property Rights

Information contained in this catalog is intended to convey examples of typical performances and/or applications of our products and is not intended to make any warranty with respect to the intellectual property rights or any other related rights of TAIYO YUDEN or any third parties nor grant any license under such rights.

■ Limited Warranty

Please note that the scope of warranty for our products is limited to the delivered our products themselves conforming to the product specifications specified in the individual product specification sheets, and TAIYO YUDEN shall not be in any way responsible for any damages resulting from a failure or defect in our products. Notwithstanding the foregoing, if there is a written agreement (e.g., supply and purchase agreement, quality assurance agreement) signed by TAIYO YUDEN and your company, TAIYO YUDEN will warrant our products in accordance with such agreement, provided, however, that our products shall be used for general-purpose and standard use in the equipment specified in this catalog or the individual product specification sheets.

■ TAIYO YUDEN's Official Sales Channel

The contents of this catalog are applicable to our products which are purchased from our sales offices or authorized distributors (hereinafter "TAIYO YUDEN's official sales channel"). Please note that the contents of this catalog are not applicable to our products purchased from any seller other than TAIYO YUDEN's official sales channel.

■ Caution for Export

Some of our products listed in this catalog may require specific procedures for export according to "U.S. Export Administration Regulations", "Foreign Exchange and Foreign Trade Control Law" of Japan, and other applicable regulations. Should you have any questions on this matter, please contact our sales staff.

▶ This catalog contains the typical specification only due to the limitation of space. When you consider the purchase of our products, please check our product specification sheets. For details of each product (characteristics graph, reliability information, precautions for use, and so on), see our website (<http://www.ty-top.com/>).

Industrial Application Guide

We have the product series (the 2nd code from the left side of the part number is “B”) intended for use in telecommunications infrastructure and industrial equipment (its typical examples are as shown in the table below). Therefore, when using our products for these equipment, please check it carefully by referring to the part number or the individual product specification sheets and use the corresponding product series. Should you have any questions on this matter, please contact us.

Product Series (The 2nd Code from the Left Side of the Part Number)	Category	Telecommunications Infrastructure and Industrial Equipment (Typical Example)
B	Telecommunications Infrastructure	<ul style="list-style-type: none"> • Base Station • Optical Transceiver • Router/Switch (Carrier-Grade) • UPS (Uninterruptible Power Supply), etc.
	Factory Automation	<ul style="list-style-type: none"> • PLC (Programmable Logic Controller) • Servomotor/Servo Driver • Industry Robot, etc.
	Measurement	<ul style="list-style-type: none"> • Gas Meter • Water Meter • Flow Meter • Pressure Gauge Meter • Magnetometer • Thermometer, etc.
	Electric Power Apparatus	<ul style="list-style-type: none"> • Power Conditioner (Solar Power System) • Smart Meter • GFCI (Ground Fault Circuit Interrupter) • Electric Vehicle Charging Station, etc.

Multilayer Ceramic Capacitors for Telecommunications Infrastructure and Industrial Equipment

REFLOW

PART NUMBER

M	B	A	S	T	3	1	L	S	B	5	1	0	6	K	T	N	A	0	1
①	②	③	④	⑤	⑥	⑦	⑧	⑨	⑩										

① Series

Code (1)(2)(3)(4)	
MBAS	Multilayer Ceramic Capacitor (High dielectric type) for Telecommunications Infrastructure and Industrial Equipment Multilayer Ceramic Capacitor (Temperature compensating type) for Telecommunications Infrastructure and Industrial Equipment Medium-High voltage Multilayer Ceramic Capacitor for Telecommunications Infrastructure and Industrial Equipment
MBAR	High frequency/Low loss Medium-High Voltage Multilayer Ceramic Capacitor for Telecommunications Infrastructure and Industrial Equipment
MBJC	Soft Termination Multilayer Ceramic Capacitor for Telecommunications Infrastructure and Industrial Equipment
MBRL	LW Reversal Decoupling Low ESL Capacitor (LWDC™) for Telecommunications Infrastructure and Industrial Equipment

(1) Product Group

Code	
M	Multilayer Ceramic Capacitor

(2) Category

Code	Recommended equipment	Quality Grade
B	Telecommunications Infrastructure and Industrial Equipment	2

(3) Type

Code	
A	2 terminals
J	Soft Termination
R	LW reversal

(4) Features, Characteristics

Code	
S	Standard/General
R	High frequency/Low loss
C	Internal code (Soft Termination)
L	Low ESL

② Rated voltage

Code	Rated voltage [VDC]
A	4
J	6.3
L	10
E	16
T	25
G	35
U	50
H	100
Q	250
S	630

④ Thickness

Code	Thickness [mm]
3	0.3
5	0.5
7	0.7
8	0.8
9	0.85
Q	1.15
G	1.25
L	1.6
N	1.9 (0.088 max ※)
M	2.5

Note : ※LW reverse type (MBRL)

③ Dimension (L × W)

Code	L × W [mm]	JIS(mm)	EIA(inch)
06	0.6 × 0.3	0603	0201
10	1.0 × 0.5	1005	0402
	0.52 × 1.0 ※	0510	0204
16	1.6 × 0.8	1608	0603
	0.8 × 1.6 ※	0816	0306
21	2.0 × 1.25	2012	0805
	1.25 × 2.0 ※	1220	0508
31	3.2 × 1.6	3216	1206
32	3.2 × 2.5	3225	1210
45	4.5 × 3.2	4532	1812

Note : ※LW reverse type (MBRL)

⑤Dimension tolerance

Code	Dimension code	L[mm]	W[mm]	T[mm]	Thickness code
A	10	1.0±0.10	0.5±0.10	0.5±0.10	5
	16	1.6+0.15/-0.05	0.8+0.15/-0.05	0.8+0.15/-0.05	8
	21	2.0+0.15/-0.05	1.25+0.15/-0.05	1.25+0.15/-0.05	G
	31	3.2±0.20	1.6±0.20	1.15±0.20	Q
	32	3.2±0.30	2.5±0.30	1.6±0.20	L
B	10	1.0+0.15/-0.05	0.5+0.15/-0.05	0.5+0.15/-0.05	5
	16	1.6+0.20/-0	0.8+0.20/-0	0.8+0.20/-0	8
	21	2.0+0.20/-0	1.25+0.20/-0	1.25+0.20/-0	G
	31	3.2±0.30	1.6±0.30	1.6±0.30	L
C	10	1.0+0.20/-0	0.5+0.20/-0	0.5+0.20/-0	5
	16	1.6+0.25/-0	0.8+0.25/-0	0.8+0.25/-0	8
	21	2.0+0.25/-0	1.25+0.25/-0	1.25+0.25/-0	G
D	21	2.0+0.30/-0	1.25+0.30/-0	1.25+0.30/-0	G
H	31	3.2±0.15	1.6±0.15	1.15±0.10	Q
J	21	2.0+0.15/-0.05	1.25+0.15/-0.05	0.85±0.10	9
L	21	2.0+0.20/-0	1.25+0.20/-0	0.85±0.10	9
	32	3.2±0.50	2.5±0.30	2.5±0.30	M
N	21	2.0±0.15	1.25±0.15	0.85±0.15	9
S	06	0.6±0.03	0.3±0.03	0.3±0.03	3
	10	1.0±0.05	0.5±0.05	0.5±0.05	5
		0.52±0.05 ※	1.0±0.05	0.3±0.05	3
	16	1.6±0.10	0.8±0.10	0.7±0.10	7
		0.8±0.10 ※	1.6±0.10	0.8±0.10	8
	21	2.0±0.10	1.25±0.10	0.5±0.05	5
		0.85±0.10		0.85±0.10	9
		1.25±0.10		1.25±0.10	G
	31	1.25±0.15 ※	2.0±0.15	0.85±0.10	9
		3.2±0.15	1.6±0.15	1.6±0.20	L
	32	3.2±0.30	2.5±0.20	1.9±0.20	N
			2.5±0.20	M	
45	4.5±0.40	3.2±0.30	2.5±0.20	M	

Note :※LW reverse type (MBRL)

⑥ Temperature characteristics code

■ High dielectric type

Code	Applicable standard		Temperature range [°C]	Ref. Temp. [°C]	Capacitance change	Capacitance tolerance	Tolerance code
B5	EIA	X5R	-55 ~ + 85	25	± 15%	± 10%	K
						± 20%	M
C6	EIA	X6S	-55 ~ + 105	25	± 22%	± 10%	K
						± 20%	M
B7	EIA	X7R	-55 ~ + 125	25	± 15%	± 10%	K
						± 20%	M
C7	EIA	X7S	-55 ~ + 125	25	± 22%	± 10%	K
						± 20%	M
D7	EIA	X7T	-55 ~ + 125	25	+ 22% / - 33%	± 10%	K
						± 20%	M

■ Temperature compensating type

Code	Applicable standard		Temperature range [°C]	Ref. Temp. [°C]	Capacitance change	Capacitance tolerance	Tolerance code
CG	JIS	CG	-55 ~ + 125	20	0 ± 30ppm/°C	± 0.05pF	A
						± 0.1pF	B
	± 0.25pF	C					
	EIA	C0G		25		± 0.5pF	D
						± 2%	G
± 5%			J				
CH	JIS	CH	-55 ~ + 125	20	0 ± 60ppm/°C	± 0.25pF	C
						± 0.5pF	D
	EIA	C0H		25		± 5%	J
CJ	JIS	CJ	-55 ~ + 125	20	0 ± 120ppm/°C	± 0.25pF	C
	EIA	C0J					
CK	JIS	CK	-55 ~ + 125	20	0 ± 250ppm/°C	± 0.25pF	C
	EIA	C0K		25			

⑦ Nominal capacitance

Code (example)	Nominal capacitance
0R5	0.5pF
010	1pF
100	10pF
101	100pF
102	1,000pF
103	0.01μF
104	0.1μF
105	1μF
106	10μF
107	100μF

Note : R=Decimal point

⑧ Capacitance tolerance

Code	Capacitance tolerance
A	± 0.05pF
B	± 0.1pF
C	± 0.25pF
D	± 0.5pF
G	± 2%
J	± 5%
K	± 10%
M	± 20%

⑨ Packaging

Code	Packaging
F	φ178mm Taping (2mm pitch)
R	φ178mm Embossed Taping (4mm pitch)
T	φ178mm Taping (4mm pitch)
P	φ178mm Taping (4mm pitch, 1000 pcs/reel) 3225 type (Thickness code M)

⑩ Internal code

STANDARD EXTERNAL DIMENSIONS

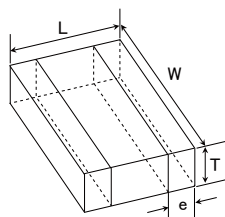
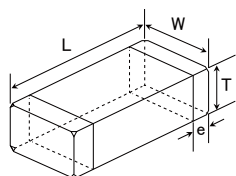

※LW reverse type

Type	JIS (mm)	EIA (inch)	Dimension [mm] (inch)				
			L	W	T	*1	e
MBAS□06	0603	0201	0.6±0.03 (0.024±0.001)	0.3±0.03 (0.012±0.001)	0.3±0.03 (0.012±0.001)	3	0.15±0.05 (0.006±0.002)
MBAR□10 MBAS□10	1005	0402	1.0±0.05 (0.039±0.002)	0.5±0.05 (0.020±0.002)	0.5±0.05 (0.020±0.002)	5	0.25±0.10 (0.010±0.004)
MBRL□10 ※	0510	0204	0.52±0.05 (0.020±0.002)	1.0±0.05 (0.039±0.002)	0.3±0.05 (0.012±0.002)	3	0.18±0.08 (0.007±0.003)
MBAS□16 MBAR□16	1608	0603	1.6±0.10 (0.063±0.004)	0.8±0.10 (0.031±0.004)	0.7±0.10 (0.028±0.004)	7	0.35±0.25 (0.014±0.010)
					0.8±0.10 (0.031±0.004)	8	
MBJC□16	1608	0603	1.6±0.10 (0.063±0.004)	0.8±0.10 (0.031±0.004)	0.8±0.10 (0.031±0.004)	8	0.35+0.3/-0.25 (0.014+0.012/-0.010)
MBRL□16 ※	0816	0306	0.8±0.10 (0.031±0.004)	1.6±0.10 (0.063±0.004)	0.5±0.05 (0.020±0.002)	5	0.25±0.15 (0.010±0.006)
MBAS□21 MBAR□21	2012	0805	2.0±0.10 (0.079±0.004)	1.25±0.10 (0.049±0.004)	0.85±0.10 (0.033±0.004)	9	0.5±0.25 (0.020±0.010)
					1.25±0.10 (0.049±0.004)	G	
MBJC□21	2012	0805	2.0±0.10 (0.079±0.004)	1.25±0.10 (0.049±0.004)	0.85±0.10 (0.033±0.004)	9	0.5+0.35/-0.25 (0.020+0.014/-0.010)
					1.25±0.10 (0.049±0.004)	G	
MBRL□21 ※	1220	0508	1.25±0.15 (0.049±0.006)	2.0±0.15 (0.079±0.006)	0.85±0.10 (0.033±0.004)	9	0.3±0.2 (0.012±0.008)
MBAS□31	3216	1206	3.2±0.15 (0.126±0.006)	1.6±0.15 (0.063±0.006)	1.15±0.10 (0.045±0.004)	Q	0.5+0.35/-0.25 (0.020+0.014/-0.010)
					1.6±0.20 (0.063±0.008)	L	
MBJC□31	3216	1206	3.2±0.15 (0.126±0.006)	1.6±0.15 (0.063±0.006)	1.15±0.10 (0.045±0.004)	Q	0.6+0.4/-0.3 (0.024+0.016/-0.012)
					1.6±0.20 (0.063±0.008)	L	
MBAS□32	3225	1210	3.2±0.30 (0.126±0.012)	2.5±0.20 (0.098±0.008)	1.9±0.20 (0.075±0.008)	N	0.6±0.3 (0.024±0.012)
					2.5±0.20 (0.098±0.008)	M	
MBJC□32	3225	1210	3.2±0.30 (0.126±0.012)	2.5±0.20 (0.098±0.008)	1.9±0.20 (0.075±0.008)	N	0.6+0.4/-0.3 (0.024+0.016/-0.012)
					2.5±0.20 (0.098±0.008)	M	
MBAS□45	4532	1812	4.5±0.40 (0.177±0.016)	3.2±0.30 (0.126±0.012)	2.5±0.20 (0.098±0.008)	M	0.9±0.6 (0.035±0.024)

Note :※LW reverse type (MBRL), *1.Thickness code

■ STANDARD QUANTITY

Type			Thickness		Standard quantity [pcs]	
Code	JIS(mm)	EIA(inch)	[mm]	Code	Paper tape	Embossed tape
06	0603	0201	0.3	3	15000	—
10	1005	0402	0.5	5	10000	—
	0510 ※	0204 ※	0.3	3		
16	1608	0603	0.7	7	4000	—
			0.8	8		
	0816 ※	0306 ※	0.5	5	—	4000
			0.8	8	3000 (Soft Termination)	3000 (Soft Termination)
21	2012	0805	0.85	9	4000	—
			1.25	G	—	3000
			1.25	G	—	2000 (Soft Termination)
	1220 ※	0508 ※	0.85	9	4000	—
31	3216	1206	1.15	Q	—	3000
			1.6	L	—	2000
32	3225	1210	1.9	N	—	2000
			2.5	M	—	500(T), 1000(P)
45	4532	1812	2.5	M	—	500

Note : ※.LW Reverse type (MBRL)

■ PART NUMBER

- All the Multilayer Ceramic Capacitors of the catalog lineup are RoHS compliant.
- Capacitance tolerance code is applied to □ of part number.
- All the Multilayer Ceramic Capacitors in the catalog lineup are applicable for reflow-soldering.

Notes)
 • The exchange of individual specifications is necessary depending on your application and/or circuit condition. Please contact TAIYO YUDEN's official sales channel.
 • The products are for Telecommunications infrastructure and Industrial equipment.
 Please consult with TAIYO YUDEN's official sales channel for the details of the product specifications, etc., and please review and approve the product specifications before ordering.
 • *1: For standard case size, please kindly refer to Dimension, Thickness, Dimension tolerance, and STANDARD EXTERNAL DIMENSIONS.

Multilayer Ceramic Capacitors (High dielectric type) for Telecommunications Infrastructure and Industrial Equipment

● 0603TYPE

【Temperature Characteristic B7 : X7R (−55~+125°C), D7 : X7T (−55~+125°C)】 0.3mm Thickness

New part number	Old part number (for reference)	Rated voltage [V]	Temperature characteristics	Capacitance [F]	Capacitance tolerance [%]	tan δ [%]	HTLT		Thickness*1 [mm]	Note
							Rated voltage x %			
MBAST063SB7101□FCA01	TMK063 B7101□PHFE	25	X7R	100 p	±10,±20	3.5	200	0.3±0.03		
MBAST063SB7151□FCA01	TMK063 B7151□PHFE		X7R	150 p	±10,±20	3.5	200	0.3±0.03		
MBAST063SB7221□FCA01	TMK063 B7221□PHFE		X7R	220 p	±10,±20	3.5	200	0.3±0.03		
MBAST063SB7331□FCA01	TMK063 B7331□PHFE		X7R	330 p	±10,±20	3.5	200	0.3±0.03		
MBAST063SB7471□FCA01	TMK063 B7471□PHFE		X7R	470 p	±10,±20	3.5	200	0.3±0.03		
MBAST063SB7681□FCA01	TMK063 B7681□PHFE		X7R	680 p	±10,±20	5	200	0.3±0.03		
MBAST063SB7102□FCA01	TMK063 B7102□PHFE		X7R	1000 p	±10,±20	5	200	0.3±0.03		
MBAST063SB7152□FCA01	TMK063 B7152□PHFE		X7R	1500 p	±10,±20	5	200	0.3±0.03		
MBAST063SB7222□FCA01	TMK063 B7222□PHFE		X7R	2200 p	±10,±20	5	200	0.3±0.03		
MBAST063SB7332□FCA01	TMK063 B7332□PHFE		X7R	3300 p	±10,±20	5	200	0.3±0.03		
MBASE063SB7101□FCA01	EMK063 B7101□PHFE		X7R	100 p	±10,±20	3.5	200	0.3±0.03		
MBASE063SB7151□FCA01	EMK063 B7151□PHFE		X7R	150 p	±10,±20	3.5	200	0.3±0.03		
MBASE063SB7221□FCA01	EMK063 B7221□PHFE		X7R	220 p	±10,±20	3.5	200	0.3±0.03		
MBASE063SB7331□FCA01	EMK063 B7331□PHFE		X7R	330 p	±10,±20	3.5	200	0.3±0.03		
MBASE063SB7471□FCA01	EMK063 B7471□PHFE		X7R	470 p	±10,±20	3.5	200	0.3±0.03		
MBASE063SB7681□FCA01	EMK063 B7681□PHFE		X7R	680 p	±10,±20	5	200	0.3±0.03		
MBASE063SB7102□FCA01	EMK063 B7102□PHFE	X7R	1000 p	±10,±20	5	200	0.3±0.03			
MBASE063SB7152□FCA01	EMK063 B7152□PHFE	X7R	1500 p	±10,±20	5	200	0.3±0.03			
MBASE063SB7222□FCA01	EMK063 B7222□PHFE	X7R	2200 p	±10,±20	5	200	0.3±0.03			
MBASE063SB7332□FCA01	EMK063 B7332□PHFE	X7R	3300 p	±10,±20	5	200	0.3±0.03			
MBASL063SB7101□FCA01	LMK063 B7101□PHFE	10	X7R	100 p	±10,±20	3.5	200	0.3±0.03		
MBASL063SB7151□FCA01	LMK063 B7151□PHFE		X7R	150 p	±10,±20	3.5	200	0.3±0.03		
MBASL063SB7221□FCA01	LMK063 B7221□PHFE		X7R	220 p	±10,±20	3.5	200	0.3±0.03		
MBASL063SB7331□FCA01	LMK063 B7331□PHFE		X7R	330 p	±10,±20	3.5	200	0.3±0.03		
MBASL063SB7471□FCA01	LMK063 B7471□PHFE		X7R	470 p	±10,±20	3.5	200	0.3±0.03		
MBASL063SB7681□FCA01	LMK063 B7681□PHFE		X7R	680 p	±10,±20	5	200	0.3±0.03		
MBASL063SB7102□FCA01	LMK063 B7102□PHFE		X7R	1000 p	±10,±20	5	200	0.3±0.03		
MBASL063SB7152□FCA01	LMK063 B7152□PHFE		X7R	1500 p	±10,±20	5	200	0.3±0.03		
MBASL063SB7222□FCA01	LMK063 B7222□PHFE		X7R	2200 p	±10,±20	5	200	0.3±0.03		
MBASL063SB7332□FCA01	LMK063 B7332□PHFE		X7R	3300 p	±10,±20	5	200	0.3±0.03		
MBASL063SB7472□FCA01	LMK063 B7472□PHFE		X7R	4700 p	±10,±20	5	200	0.3±0.03		
MBASL063SB7682□FCA01	LMK063 B7682□PHFE		X7R	6800 p	±10,±20	5	200	0.3±0.03		
MBASL063SB7103□FCA01	LMK063 B7103□PHFE		X7R	0.01 μ	±10,±20	5	200	0.3±0.03		
MBASJ063SD7223□FCA01	JMK063 D7223□PHFE		6.3	X7T	0.022 μ	±10,±20	7.5	200	0.3±0.03	
MBASJ063SD7333□FCA01	JMK063 D7333□PHFE			X7T	0.033 μ	±10,±20	7.5	200	0.3±0.03	
MBASJ063SD7473□FCA01	JMK063 D7473□PHFE			X7T	0.047 μ	±10,±20	7.5	200	0.3±0.03	
MBASJ063SD7104□FCA01	JMK063 D7104□PHFE	X7T		0.1 μ	±10,±20	10	200	0.3±0.03		

▶ This catalog contains the typical specification only due to the limitation of space. When you consider the purchase of our products, please check our specification. For details of each product (characteristics graph, reliability information, precautions for use, and so on), see our Web site (<http://www.ty-top.com/>).

■ PART NUMBER

● 1005TYPE

【Temperature Characteristic B5 (BJ) : X5R (−55~+85°C)】 0.5mm Thickness

New part number	Old part number (for reference)	Rated voltage [V]	Temperature characteristics	Capacitance [F]	Capacitance tolerance [%]	tan δ [%]	HTLT	Thickness*1 [mm]	Note
							Rated voltage x %		
MBASU105SB5471□FNA01	UMK105 BJ471□VHF	50	X5R	470 p	±10, ±20	2.5	200	0.5±0.05	
MBASU105SB5102□FNA01	UMK105 BJ102□VHF		X5R	1000 p	±10, ±20	2.5	200	0.5±0.05	
MBASU105SB5152□FNA01	UMK105 BJ152□VHF		X5R	1500 p	±10, ±20	2.5	200	0.5±0.05	
MBASU105SB5222□FNA01	UMK105 BJ222□VHF		X5R	2200 p	±10, ±20	2.5	200	0.5±0.05	
MBASU105SB5332□FNA01	UMK105 BJ332□VHF		X5R	3300 p	±10, ±20	2.5	200	0.5±0.05	
MBASU105SB5472□FNA01	UMK105 BJ472□VHF		X5R	4700 p	±10, ±20	2.5	200	0.5±0.05	
MBASU105SB5682□FNA01	UMK105 BJ682□VHF		X5R	6800 p	±10, ±20	2.5	150	0.5±0.05	
MBASU105SB5103□FNA01	UMK105 BJ103□VHF		X5R	0.01 μ	±10, ±20	3.5	200	0.5±0.05	
MBASU105SB5223□FNA01	UMK105 BJ223□VHF		X5R	0.022 μ	±10, ±20	5	200	0.5±0.05	
MBASU105SB5473□FNA01	UMK105 BJ473□VHF		X5R	0.047 μ	±10, ±20	5	200	0.5±0.05	
MBASU105SB5104□FNA01	UMK105 BJ104□VHF		X5R	0.1 μ	±10, ±20	10	150	0.5±0.05	
MBAST105SB5472□FNA01	TMK105 BJ472□VHF		X5R	4700 p	±10, ±20	2.5	200	0.5±0.05	
MBAST105SB5682□FNA01	TMK105 BJ682□VHF		X5R	6800 p	±10, ±20	2.5	200	0.5±0.05	
MBAST105SB5103□FNA01	TMK105 BJ103□VHF		X5R	0.01 μ	±10, ±20	3.5	200	0.5±0.05	
MBAST105SB5153□FNA01	TMK105 BJ153□VHF	X5R	0.015 μ	±10, ±20	3.5	200	0.5±0.05		
MBAST105SB5223□FNA01	TMK105 BJ223□VHF	X5R	0.022 μ	±10, ±20	3.5	200	0.5±0.05		
MBAST105SB5333□FNA01	TMK105 BJ333□VHF	X5R	0.033 μ	±10, ±20	3.5	150	0.5±0.05		
MBAST105SB5473□FNA01	TMK105 BJ473□VHF	X5R	0.047 μ	±10, ±20	3.5	150	0.5±0.05		
MBAST105SB5104□FNA01	TMK105 BJ104□VHF	X5R	0.1 μ	±10, ±20	5	150	0.5±0.05		
MBAST105SB5224□FNA01	TMK105 BJ224□VHF	X5R	0.22 μ	±10, ±20	10	150	0.5±0.05		
MBAST105AB5474□FNA01	TMK105ABJ474□VHF	X5R	0.47 μ	±10, ±20	10	150	0.5±0.10		
MBASE105SB5104□FNA01	EMK105 BJ104□VHF	X5R	0.1 μ	±10, ±20	5	150	0.5±0.05		
MBASE105SB5224□FNA01	EMK105 BJ224□VHF	X5R	0.22 μ	±10, ±20	10	150	0.5±0.05		
MBASE105AB5474□FNA01	EMK105ABJ474□VHF	X5R	0.47 μ	±10, ±20	10	150	0.5±0.10		
MBASE105SB5105□FNA01	EMK105 BJ105□VHF	X5R	1 μ	±10, ±20	10	150	0.5±0.05		
MBASL105SB5224□FNA01	LMK105 BJ224□VHF	X5R	0.22 μ	±10, ±20	5	150	0.5±0.05		
MBASL105AB5474□FNA01	LMK105ABJ474□VHF	X5R	0.47 μ	±10, ±20	10	150	0.5±0.10		
MBASL105SB5105□FNA01	LMK105 BJ105□VHF	X5R	1 μ	±10, ±20	10	150	0.5±0.05		
MBASL105AB5225□FNA01	LMK105ABJ225□VHF	X5R	2.2 μ	±10, ±20	10	150	0.5±0.10		
MBASJ105SB5474□FNA01	JMK105 BJ474□VHF	X5R	0.47 μ	±10, ±20	10	150	0.5±0.05		
MBASJ105SB5105□FNA01	JMK105 BJ105□VHF	X5R	1 μ	±10, ±20	10	150	0.5±0.05		
MBASJ105SB5225□FNA01	JMK105 BJ225□VHF	X5R	2.2 μ	±10, ±20	10	150	0.5±0.05		
MBASJ105BB5475MFNA01	JMK105BBJ475MVHF	X5R	4.7 μ	±20	10	150	0.5+0.15/-0.05		
MBASA105SB5225□FNA01	AMK105 BJ225□VHF	X5R	2.2 μ	±10, ±20	10	150	0.5±0.05		
MBASA105BB5475MFNA01	AMK105BBJ475MVHF	X5R	4.7 μ	±20	10	150	0.5+0.15/-0.05		

【Temperature Characteristic C6 : X6S (−55~+105°C)】 0.5mm Thickness

New part number	Old part number (for reference)	Rated voltage [V]	Temperature characteristics	Capacitance [F]	Capacitance tolerance [%]	tan δ [%]	HTLT	Thickness*1 [mm]	Note
							Rated voltage x %		
MBASE105AC6474□FNA01	EMK105AC6474□VHF	16	X6S	0.47 μ	±10, ±20	10	150	0.5±0.10	
MBASL105SC6105□FNA01	LMK105 C6105□VHF	10	X6S	1 μ	±10, ±20	10	150	0.5±0.05	
MBASJ105SC6105□FNA01	JMK105 C6105□VHF	6.3	X6S	1 μ	±10, ±20	10	150	0.5±0.05	

▶ This catalog contains the typical specification only due to the limitation of space. When you consider the purchase of our products, please check our specification.
For details of each product (characteristics graph, reliability information, precautions for use, and so on), see our Web site (<http://www.ty-top.com/>).

■ PART NUMBER

【Temperature Characteristic B7 : X7R(-55~+125°C), D7 : X7T(-55~+125°C)】 0.5mm Thickness

New part number	Old part number (for reference)	Rated voltage [V]	Temperature characteristics	Capacitance [F]	Capacitance tolerance [%]	tan δ [%]	HTLT	Thickness*1 [mm]	Note		
							Rated voltage x %				
MBASU105SB7221□FNA01	UMK105 B7221□VHF	50	X7R	220 p	±10, ±20	2.5	200	0.5±0.05			
MBASU105SB7331□FNA01	UMK105 B7331□VHF		X7R	330 p	±10, ±20	2.5	200	0.5±0.05			
MBASU105SB7471□FNA01	UMK105 B7471□VHF		X7R	470 p	±10, ±20	2.5	200	0.5±0.05			
MBASU105SB7681□FNA01	UMK105 B7681□VHF		X7R	680 p	±10, ±20	2.5	200	0.5±0.05			
MBASU105SB7102□FNA01	UMK105 B7102□VHF		X7R	1000 p	±10, ±20	2.5	200	0.5±0.05			
MBASU105SB7152□FNA01	UMK105 B7152□VHF		X7R	1500 p	±10, ±20	2.5	200	0.5±0.05			
MBASU105SB7222□FNA01	UMK105 B7222□VHF		X7R	2200 p	±10, ±20	2.5	200	0.5±0.05			
MBASU105SB7332□FNA01	UMK105 B7332□VHF		X7R	3300 p	±10, ±20	2.5	200	0.5±0.05			
MBASU105SB7472□FNA01	UMK105 B7472□VHF		X7R	4700 p	±10, ±20	2.5	150	0.5±0.05			
MBASU105SB7682□FNA01	UMK105 B7682□VHF		X7R	6800 p	±10, ±20	2.5	150	0.5±0.05			
MBASU105SB7103□FNA01	UMK105 B7103□VHF		X7R	0.01 μ	±10, ±20	3.5	150	0.5±0.05			
MBASU105SB7153□FCA01	UMK105 B7153□VHF		X7R	0.015 μ	±10, ±20	3.5	200	0.5±0.05			
MBASU105SB7223□FNA01	UMK105 B7223□VHF		X7R	0.022 μ	±10, ±20	10	200	0.5±0.05			
MBASU105SB7333□FCA01	UMK105 B7333□VHFE		X7R	0.033 μ	±10, ±20	3.5	150	0.5±0.05			
MBASU105SB7473□FNA01	UMK105 B7473□VHF		X7R	0.047 μ	±10, ±20	10	200	0.5±0.05			
MBASU105AB7683□FCA01	UMK105AB7683□VHFE		X7R	0.068 μ	±10, ±20	5	150	0.5±0.1			
MBASU105SB7104□FNA01	UMK105 B7104□VHF		X7R	0.1 μ	±10, ±20	10	150	0.5±0.05			
MBAST105SB7472□FNA01	TMK105 B7472□VHF		25	X7R	4700 p	±10, ±20	2.5	200	0.5±0.05		
MBAST105SB7682□FNA01	TMK105 B7682□VHF			X7R	6800 p	±10, ±20	2.5	200	0.5±0.05		
MBAST105SB7103□FNA01	TMK105 B7103□VHF			X7R	0.01 μ	±10, ±20	3.5	200	0.5±0.05		
MBAST105SB7153□FNA01	TMK105 B7153□VHF			X7R	0.015 μ	±10, ±20	3.5	150	0.5±0.05		
MBAST105SB7223□FNA01	TMK105 B7223□VHF			X7R	0.022 μ	±10, ±20	3.5	150	0.5±0.05		
MBAST105SB7333□FNA01	TMK105 B7333□VHF			X7R	0.033 μ	±10, ±20	3.5	150	0.5±0.05		
MBAST105SB7473□FNA01	TMK105 B7473□VHF			X7R	0.047 μ	±10, ±20	3.5	150	0.5±0.05		
MBAST105AB7683□FCA01	TMK105AB7683□VHFE			X7R	0.068 μ	±10, ±20	5	200	0.5±0.1		
MBAST105SB7104□FNA01	TMK105 B7104□VHF	X7R		0.1 μ	±10, ±20	10	150	0.5±0.05			
MBASE105SB7103□FNA01	EMK105 B7103□VHF	16		X7R	0.01 μ	±10, ±20	3.5	200	0.5±0.05		
MBASE105SB7153□FNA01	EMK105 B7153□VHF			X7R	0.015 μ	±10, ±20	3.5	150	0.5±0.05		
MBASE105SB7223□FNA01	EMK105 B7223□VHF			X7R	0.022 μ	±10, ±20	3.5	150	0.5±0.05		
MBASE105SB7333□FNA01	EMK105 B7333□VHF			X7R	0.033 μ	±10, ±20	3.5	150	0.5±0.05		
MBASE105SB7473□FNA01	EMK105 B7473□VHF			X7R	0.047 μ	±10, ±20	3.5	150	0.5±0.05		
MBASE105SB7104□FNA01	EMK105 B7104□VHF			X7R	0.1 μ	±10, ±20	5	150	0.5±0.05		
MBASE105SB7224□FNA01	EMK105 B7224□VHF			X7R	0.22 μ	±10, ±20	10	150	0.5±0.05		
MBASL105SB7473□FNA01	LMK105 B7473□VHF			10	X7R	0.047 μ	±10, ±20	3.5	150	0.5±0.05	
MBASL105SB7104□FNA01	LMK105 B7104□VHF				X7R	0.1 μ	±10, ±20	5	150	0.5±0.05	
MBASL105SB7224□FNA01	LMK105 B7224□VHF				X7R	0.22 μ	±10, ±20	10	150	0.5±0.05	
MBASL105AD7474□FCA01	LMK105AD7474□VHFE	X7T			0.47 μ	±10, ±20	10	150	0.5±0.10		
MBASL105CD7105□FCA01	LMK105CD7105□VHFE	X7T			1 μ	±10, ±20	10	150	0.5+0.20/-0		
MBASJ105SB7104□FNA01	JMK105 B7104□VHF	6.3		X7R	0.1 μ	±10, ±20	5	150	0.5±0.05		
MBASJ105SB7224□FNA01	JMK105 B7224□VHF			X7R	0.22 μ	±10, ±20	10	150	0.5±0.05		
MBASJ105SB7474□FNA01	JMK105 B7474□VHF			X7R	0.47 μ	±10, ±20	10	150	0.5±0.05		
MBASJ105CD7105□FNA01	JMK105CD7105□VHF			X7T	1 μ	±10, ±20	10	150	0.5+0.20/-0		
MBASA105SB7474□FNA01	AMK105 B7474□VHF		4	X7R	0.47 μ	±10, ±20	10	150	0.5±0.05		

● 1608TYPE

【Temperature Characteristic B5(BJ) : X5R(-55~+85°C)】 0.8mm Thickness

New part number	Old part number (for reference)	Rated voltage [V]	Temperature characteristics	Capacitance [F]	Capacitance tolerance [%]	tan δ [%]	HTLT	Thickness*1 [mm]	Note
							Rated voltage x %		
MBASU168SB5224□TNA01	UMK107 BJ224□AHT	50	X5R	0.22 μ	±10, ±20	10	150	0.8±0.10	
MBASU168SB5474□TNA01	UMK107 BJ474□AHT		X5R	0.47 μ	±10, ±20	10	150	0.8±0.10	
MBASU168AB5105□TNA01	UMK107ABJ105□AHT		X5R	1 μ	±10, ±20	10	150	0.8+0.15/-0.05	
MBASG168SB5224□TNA01	GMK107 BJ224□AHT		X5R	0.22 μ	±10, ±20	10	150	0.8±0.10	
MBASG168AB5474□TNA01	GMK107ABJ474□AHT		X5R	0.47 μ	±10, ±20	10	150	0.8+0.15/-0.05	
MBASG168SB5105□TNA01	GMK107 BJ105□AHT	35	X5R	1 μ	±10, ±20	10	150	0.8±0.10	
MBAST168SB5224□TNA01	TMK107 BJ224□AHT		X5R	0.22 μ	±10, ±20	5	150	0.8±0.10	
MBAST168SB5474□TNA01	TMK107 BJ474□AHT		X5R	0.47 μ	±10, ±20	3.5	150	0.8±0.10	
MBAST168SB5105□TNA01	TMK107 BJ105□AHT		X5R	1 μ	±10, ±20	10	150	0.8±0.10	
MBAST168BB5225□TNA01	TMK107BBJ225□AHT		X5R	2.2 μ	±10, ±20	10	150	0.8+0.20/-0	
MBASE168SB5105□TNA01	EMK107 BJ105□AHT	25	X5R	1 μ	±10, ±20	5	150	0.8±0.10	
MBASE168AB5225□TNA01	EMK107ABJ225□AHT		X5R	2.2 μ	±10, ±20	10	150	0.8+0.15/-0.05	
MBASE168BB5475□TNA01	EMK107BBJ475□AHT		X5R	4.7 μ	±10, ±20	10	150	0.8+0.20/-0	
MBASL168SB5225□TNA01	LMK107 BJ225□AHT		X5R	2.2 μ	±10, ±20	10	150	0.8±0.10	
MBASL168SB5475□TNA01	LMK107 BJ475□AHT		X5R	4.7 μ	±10, ±20	10	150	0.8±0.10	
MBASL168BB5106MTNA01	LMK107BBJ106MAHT	10	X5R	10 μ	±20	10	150	0.8+0.20/-0	
MBASJ168SB5475□TNA01	JMK107 BJ475□AHT		X5R	4.7 μ	±10, ±20	10	150	0.8±0.10	
MBASJ168AB5106□TNA01	JMK107ABJ106□AHT		X5R	10 μ	±10, ±20	10	150	0.8+0.15/-0.05	
MBASA168AB5106□TNA01	AMK107ABJ106□AHT		X5R	10 μ	±10, ±20	10	150	0.8+0.15/-0.05	
MBASA168BB5226MTNA01	AMK107BBJ226MAHT		4	X5R	22 μ	±20	10	150	0.8+0.20/-0

【Temperature Characteristic C6 : X6S(-55~+105°C)】 0.8mm Thickness

New part number	Old part number (for reference)	Rated voltage [V]	Temperature characteristics	Capacitance [F]	Capacitance tolerance [%]	tan δ [%]	HTLT	Thickness*1 [mm]	Note
							Rated voltage x %		
MBASL168SC6225□TNA01	LMK107 C6225□AHT	10	X6S	2.2 μ	±10, ±20	10	150	0.8±0.10	
MBASJ168AC6475□TNA01	JMK107AC6475□AHT	6.3	X6S	4.7 μ	±10, ±20	10	150	0.8+0.15/-0.05	
MBASJ168BC6106MTNA01	JMK107BC6106MAHT		X6S	10 μ	±20	10	150	0.8+0.20/-0	

▶ This catalog contains the typical specification only due to the limitation of space. When you consider the purchase of our products, please check our specification.
For details of each product (characteristics graph, reliability information, precautions for use, and so on), see our Web site (<http://www.ty-top.com/>).

■ PART NUMBER

【Temperature Characteristic B7 : X7R(-55~+125°C), C7 : X7S(-55~+125°C), D7 : X7T(-55~+125°C)】 0.8mm Thickness

New part number	Old part number (for reference)	Rated voltage [V]	Temperature characteristics	Capacitance [F]	Capacitance tolerance [%]	tan δ [%]	HTLT	Thickness*1 [mm]	Note
							Rated voltage x %		
MBASU168AC7154□TCA01	UMK107AC7154□AHTE	50	X7S	0.15 μ	±10, ±20	3.5	150	0.8±0.15/-0.05	
MBASU168SC7224□TCA01	UMK107 C7224□AHTE		X7S	0.22 μ	±10, ±20	3.5	150	0.8±0.10	
MBASU168SB7474□TCA01	UMK107 B7474□AHTE		X7R	0.47 μ	±10, ±20	10	150	0.8±0.10	
MBASG168SB7224□TNA01	GMK107 B7224□AHT	35	X7R	0.22 μ	±10, ±20	10	150	0.8±0.10	
MBASG168SB7474□TNA01	GMK107 B7474□AHT		X7R	0.47 μ	±10, ±20	10	150	0.8±0.10	
MBASG168AB7105□TNA01	GMK107AB7105□AHT		X7R	1 μ	±10, ±20	10	150	0.8±0.15/-0.05	
MBAST168SB7224□TNA01	TMK107 B7224□AHT	25	X7R	0.22 μ	±10, ±20	10	150	0.8±0.10	
MBAST168SB7474□TNA01	TMK107 B7474□AHT		X7R	0.47 μ	±10, ±20	10	150	0.8±0.10	
MBAST168AB7105□TNA01	TMK107AB7105□AHT		X7R	1 μ	±10, ±20	10	150	0.8±0.15/-0.05	
MBASE168SB7224□TNA01	EMK107 B7224□AHT	16	X7R	0.22 μ	±10, ±20	5	150	0.8±0.10	
MBASE168SB7474□TNA01	EMK107 B7474□AHT		X7R	0.47 μ	±10, ±20	10	150	0.8±0.10	
MBASE168SB7105□TNA01	EMK107 B7105□AHT		X7R	1 μ	±10, ±20	10	150	0.8±0.10	
MBASL168SB7474□TNA01	LMK107 B7474□AHT	10	X7R	0.47 μ	±10, ±20	3.5	150	0.8±0.10	
MBASL168SB7105□TNA01	LMK107 B7105□AHT		X7R	1 μ	±10, ±20	10	150	0.8±0.10	
MBASL168BD7225□TNA01	LMK107BD7225□AHT		X7T	2.2 μ	±10, ±20	10	200	0.8±0.20/-0	
MBASJ168SB7105□TNA01	JMK107 B7105□AHT	6.3	X7R	1 μ	±10, ±20	10	150	0.8±0.10	
MBASJ168SB7225□TNB25	JMK107 B7225□AHTR		X7R	2.2 μ	±10, ±20	10	150	0.8±0.10	

● 2012TYPE

【Temperature Characteristic B5(BJ) : X5R(-55~+85°C)】 1.25mm Thickness

New part number	Old part number (for reference)	Rated voltage [V]	Temperature characteristics	Capacitance [F]	Capacitance tolerance [%]	tan δ [%]	HTLT	Thickness*1 [mm]	Note
							Rated voltage x %		
MBASU21GSB5474□TNA01	UMK212 BJ474□GHT	50	X5R	0.47 μ	±10, ±20	3.5	150	1.25±0.10	
MBASU21GSB5105□TNA01	UMK212 BJ105□GHT		X5R	1 μ	±10, ±20	5	150	1.25±0.10	
MBASG21GSB5105□TNA01	GMK212 BJ105□GHT		X5R	1 μ	±10, ±20	5	150	1.25±0.10	
MBASG21GGB5225□TNA01	GMK212BBJ225□GHT	35	X5R	2.2 μ	±10, ±20	10	150	1.25±0.20/-0	
MBAST21GSB5225□TNA01	TMK212 BJ225□GHT		X5R	2.2 μ	±10, ±20	5	150	1.25±0.10	
MBAST21GGB5475□TNA01	TMK212BBJ475□GHT		X5R	4.7 μ	±10, ±20	10	150	1.25±0.20/-0	
MBAST21GGB5106□TNA01	TMK212BBJ106□GHT	25	X5R	10 μ	±10, ±20	10	150	1.25±0.20/-0	
MBASE21GSB5225□TNA01	EMK212 BJ225□GHT		X5R	2.2 μ	±10, ±20	5	150	1.25±0.10	
MBASE21GAB5475□TNA01	EMK212ABJ475□GHT		X5R	4.7 μ	±10, ±20	10	150	1.25±0.15/-0.05	
MBASE21GGB5106□TNA01	EMK212BBJ106□GHT	16	X5R	10 μ	±10, ±20	10	150	1.25±0.20/-0	
MBASL21GAB5475□TNA01	LMK212ABJ475□GHT		X5R	4.7 μ	±10, ±20	10	150	1.25±0.15/-0.05	
MBASL21GAB5106□TNA01	LMK212ABJ106□GHT		X5R	10 μ	±10, ±20	10	150	1.25±0.15/-0.05	
MBASJ21GAB5106□TNA01	JMK212ABJ106□GHT	6.3	X5R	10 μ	±10, ±20	10	150	1.25±0.15/-0.05	
MBASJ21GGB5226MTNA01	UMK212BBJ226MGHT		X5R	22 μ	±20	10	150	1.25±0.20/-0	
MBASA21GGB5476MTNA01	AMK212BBJ476MGHT		4	X5R	47 μ	±20	10	150	1.25±0.20/-0

【Temperature Characteristic B5(BJ) : X5R(-55~+85°C)】 0.85mm Thickness

New part number	Old part number (for reference)	Rated voltage [V]	Temperature characteristics	Capacitance [F]	Capacitance tolerance [%]	tan δ [%]	HTLT	Thickness*1 [mm]	Note
							Rated voltage x %		
MBASE219JB5225□TNA01	EMK212ABJ225□DHT	16	X5R	2.2 μ	±10, ±20	5	150	0.85±0.10	
MBASE219LB5475□TNA01	EMK212BBJ475□DHT		X5R	4.7 μ	±10, ±20	10	150	0.85±0.10	

【Temperature Characteristic C6 : X6S(-55~+105°C)】 1.25mm Thickness

New part number	Old part number (for reference)	Rated voltage [V]	Temperature characteristics	Capacitance [F]	Capacitance tolerance [%]	tan δ [%]	HTLT	Thickness*1 [mm]	Note
							Rated voltage x %		
MBASL21GBC6106□TNA01	LMK212BC6106□GHT	10	X6S	10 μ	±10, ±20	10	150	1.25±0.20/-0	
MBASA21GBC6226MTNA01	AMK212BC6226MGHT	4	X6S	22 μ	±20	10	150	1.25±0.20/-0	

【Temperature Characteristic B7 : X7R(-55~+125°C), C7 : X7S(-55~+125°C)】 1.25mm Thickness

New part number	Old part number (for reference)	Rated voltage [V]	Temperature characteristics	Capacitance [F]	Capacitance tolerance [%]	tan δ [%]	HTLT	Thickness*1 [mm]	Note	
							Rated voltage x %			
MBASU21GSB7473□TNA01	UMK212 B7473□GHT	50	X7R	0.047 μ	±10, ±20	3.5	200	1.25±0.10		
MBASU21GSB7683□TNA01	UMK212 B7683□GHT		X7R	0.068 μ	±10, ±20	3.5	200	1.25±0.10		
MBASU21GSB7104□TNA01	UMK212 B7104□GHT		X7R	0.1 μ	±10, ±20	3.5	200	1.25±0.10		
MBASU21GGB7154□TCA01	UMK212BB7154□GHTE		X7R	0.15 μ	±10, ±20	3.5	200	1.25±0.2/-0		
MBASU21GSB7224□TNA01	UMK212 B7224□GHT		X7R	0.22 μ	±10, ±20	3.5	150	1.25±0.10		
MBASU21GBC7334□TCA01	UMK212BC7334□GHTE		X7S	0.33 μ	±10, ±20	3.5	150	1.25±0.2/-0		
MBASU21GSC7474□TCA01	UMK212 C7474□GHTE		X7S	0.47 μ	±10, ±20	3.5	150	1.25±0.10		
MBASU21GCC7684□TCA01	UMK212CC7684□GHTE		X7S	0.68 μ	±10, ±20	3.5	150	1.25±0.25/-0		
MBASU21GSB7105□TNA01	UMK212 B7105□GHT		X7R	1 μ	±10, ±20	10	150	1.25±0.10		
MBASG21GSB7105□TNA01	GMK212 B7105□GHT		35	X7R	1 μ	±10, ±20	10	150	1.25±0.10	
MBAST21GSB7474□TNA01	TMK212 B7474□GHT			X7R	0.47 μ	±10, ±20	3.5	150	1.25±0.10	
MBAST21GSB7105□TNB25	TMK212 B7105□GHTR		25	X7R	1 μ	±10, ±20	10	150	1.25±0.10	
MBAST21GSB7225□TNA01	TMK212 B7225□GHT	X7R		2.2 μ	±10, ±20	10	150	1.25±0.10		
MBASE21GSB7105□TNB25	EMK212 B7105□GHTR	16	X7R	1 μ	±10, ±20	10	150	1.25±0.10		
MBASE21GSB7225□TNA01	EMK212 B7225□GHT		X7R	2.2 μ	±10, ±20	10	150	1.25±0.10		
MBASE21GAB7475□TNA01	EMK212AB7475□GHT		X7R	4.7 μ	±10, ±20	10	150	1.25±0.15/-0.05		
MBASL21GSB7225□TNA01	LMK212 B7225□GHT	10	X7R	2.2 μ	±10, ±20	10	150	1.25±0.10		
MBASL21GSB7475□TNA01	LMK212 B7475□GHT		X7R	4.7 μ	±10, ±20	10	150	1.25±0.10		
MBASL21GGB7106□TNA01	LMK212BB7106□GHT		X7R	10 μ	±10, ±20	10	150	1.25±0.2/-0		
MBASJ21GSB7475□TNA01	JMK212 B7475□GHT	6.3	X7R	4.7 μ	±10, ±20	10	150	1.25±0.10		
MBASJ21GAB7106□TNA01	JMK212AB7106□GHT		X7R	10 μ	±10, ±20	10	150	1.25±0.15/-0.05		

▶ This catalog contains the typical specification only due to the limitation of space. When you consider the purchase of our products, please check our specification.
For details of each product (characteristics graph, reliability information, precautions for use, and so on), see our Web site (<http://www.ty-top.com/>).

■ PART NUMBER

● 3216TYPE

【Temperature Characteristic B5(BJ) : X5R(−55~+85°C)】 1.6mm Thickness

New part number	Old part number (for reference)	Rated voltage [V]	Temperature characteristics	Capacitance [F]	Capacitance tolerance [%]	tan δ [%]	HTLT	Thickness*1 [mm]	Note
							Rated voltage x %		
MBASU31LSB5225□TNA01	UMK316 BJ225□LHT	50	X5R	2.2 μ	±10, ±20	10	150	1.6±0.20	
MBASU31LAB5475□TNA01	UMK316ABJ475□LHT		X5R	4.7 μ	±10, ±20	10	150	1.6±0.20	
MBASG31LSB5225□TNA01	GMK316 BJ225□LHT	35	X5R	2.2 μ	±10, ±20	10	150	1.6±0.20	
MBASG31LSB5475□TNA01	GMK316 BJ475□LHT		X5R	4.7 μ	±10, ±20	10	150	1.6±0.20	
MBASG31LBB5106□TNA01	GMK316BBJ106□LHT	25	X5R	10 μ	±10, ±20	10	150	1.6±0.30	
MBAST31LSB5475□TNA01	TMK316 BJ475□LHT		X5R	4.7 μ	±10, ±20	5	150	1.6±0.20	
MBAST31LSB5106□TNA01	TMK316 BJ106□LHT	16	X5R	10 μ	±10, ±20	5	150	1.6±0.20	
MBASE31LSB5475□TNA01	EMK316 BJ475□LHT		X5R	4.7 μ	±10, ±20	5	150	1.6±0.20	
MBASE31LSB5106□TNA01	EMK316 BJ106□LHT	10	X5R	10 μ	±10, ±20	5	150	1.6±0.20	
MBASE31LBB5226MTNA01	EMK316BBJ226MLHT		X5R	22 μ	±20	10	150	1.6±0.30	
MBASL31LAB5226□TNA01	LMK316ABJ226□LHT	6.3	X5R	22 μ	±10, ±20	10	150	1.6±0.20	
MBASJ31LAB5476MTNA01	JMK316ABJ476MLHT		X5R	47 μ	±20	10	150	1.6±0.20	
MBASJ31LBB5107MTNA01	JMK316BBJ107MLHT	4	X5R	100 μ	±20	10	150	1.6±0.20	
MBASA31LAB5107MTNA01	JMK316ABJ107MLHT		X5R	100 μ	±20	10	150	1.6±0.20	

【Temperature Characteristic B7 : X7R(−55~+125°C), C7 : X7S(−55~+125°C)】 1.6mm Thickness

New part number	Old part number (for reference)	Rated voltage [V]	Temperature characteristics	Capacitance [F]	Capacitance tolerance [%]	tan δ [%]	HTLT	Thickness*1 [mm]	Note
							Rated voltage x %		
MBASU31LSB7105□TNA01	UMK316 B7105□LHT	50	X7R	1 μ	±10, ±20	3.5	200	1.6±0.20	
MBASU31LBC7155□TCA01	UMK316BC7155□LHTE		X7S	1.5 μ	±10, ±20	3.5	150	1.6±0.30	
MBASU31LSB7225□TNA01	UMK316 B7225□LHT	35	X7R	2.2 μ	±10, ±20	10	150	1.6±0.20	
MBASG31LAC7475□TCA01	UMK316AC7475□LHTE		X7S	4.7 μ	±10, ±20	2.5	150	1.6±0.20	
MBASG31LSB7225□TNA01	GMK316 B7225□LHT	25	X7R	2.2 μ	±10, ±20	10	150	1.6±0.20	
MBASG31LAB7475□TNA01	GMK316AB7475□LHT		X7R	4.7 μ	±10, ±20	10	150	1.6±0.20	
MBAST31LAB7475□TNA01	TMK316AB7475□LHT	16	X7R	4.7 μ	±10, ±20	10	150	1.6±0.20	
MBAST31LAB7106□TNA01	TMK316AB7106□LHT		X7R	10 μ	±10, ±20	10	150	1.6±0.20	
MBASE31LAB7475□TNA01	EMK316AB7475□LHT	10	X7R	4.7 μ	±10, ±20	10	150	1.6±0.20	
MBASE31LAB7106□TNA01	EMK316AB7106□LHT		X7R	10 μ	±10, ±20	10	150	1.6±0.20	
MBASL31LAB7106□TNA01	LMK316AB7106□LHT	6.3	X7R	10 μ	±10, ±20	10	150	1.6±0.20	
MBASJ31LAB7226□TNA01	JMK316AB7226□LHT		X7R	22 μ	±10, ±20	10	150	1.6±0.20	
MBASA31LAB7226□TNA01	AMK316AB7226□LHT	4	X7R	22 μ	±10, ±20	10	150	1.6±0.20	
MBASA31LAC7476MTNA01	AMK316AC7476MLHT		X7S	47 μ	±20	10	150	1.6±0.20	

● 3225TYPE

【Temperature Characteristic B5(BJ) : X5R(−55~+85°C)】 2.5mm Thickness(M)

New part number	Old part number (for reference)	Rated voltage [V]	Temperature characteristics	Capacitance [F]	Capacitance tolerance [%]	tan δ [%]	HTLT	Thickness*1 [mm]	Note
							Rated voltage x %		
MBASU32MSB5106□PNA01	UMK325 BJ106□MHP	50	X5R	10 μ	±10, ±20	5	150	2.5±0.20	
MBASE32MAB5476□PNDT1	EMK325ABJ476□MHHP	16	X5R	47 μ	±10, ±20	10	150	2.5±0.30	
MBASL32MSB5476□PNA01	LMK325 BJ476□MHP	10	X5R	47 μ	±10, ±20	10	150	2.5±0.20	
MBASL32MAB5107MPNA01	JMK325ABJ107MPNA01		X5R	100 μ	±20	10	150	2.5±0.30	
MBASJ32MAB5107MPNA01	JMK325ABJ107MPNA01	6.3	X5R	100 μ	±20	10	150	2.5±0.30	
MBASA32MAB5107MPNA01	JMK325ABJ107MPNA01	4	X5R	100 μ	±20	10	150	2.5±0.30	

【Temperature Characteristic C6 : X6S(−55~+105°C)】 2.5mm Thickness(M)

New part number	Old part number (for reference)	Rated voltage [V]	Temperature characteristics	Capacitance [F]	Capacitance tolerance [%]	tan δ [%]	HTLT	Thickness*1 [mm]	Note
							Rated voltage x %		
MBASJ32MAC6107MPNA01		6.3	X6S	100 μ	±20	10	150		

【Temperature Characteristic B7 : X7R(−55~+125°C)】 2.5mm Thickness(M)

New part number	Old part number (for reference)	Rated voltage [V]	Temperature characteristics	Capacitance [F]	Capacitance tolerance [%]	tan δ [%]	HTLT	Thickness*1 [mm]	Note
							Rated voltage x %		
MBASU32MSB7475□PNA01	UMK325 B7475□MHP	50	X7R	4.7 μ	±10, ±20	5	150	2.5±0.20	
MBASU32MAB7106□PNA01	UMK325AB7106□MHHP		X7R	10 μ	±10, ±20	10	150	2.5±0.30	
MBASG32MAB7106□PNA01	GMK325AB7106□JMHP	35	X7R	10 μ	±10, ±20	10	150	2.5±0.30	
MBAST32MAB7106□PNB25	TMK325AB7106□JMHP	25	X7R	10 μ	±10, ±20	10	150	2.5±0.30	
MBAST32MSB7226□PNA01	TMK325 B7226□MHP		X7R	22 μ	±10, ±20	10	150	2.5±0.20	
MBASE32MSB7226□PNA01	EMK325 B7226□MHP	16	X7R	22 μ	±10, ±20	10	150	2.5±0.20	
MBASL32MSB7226□PNA01	LMK325 B7226□MHP	10	X7R	22 μ	±10, ±20	10	150	2.5±0.20	
MBASJ32MSB7476□PNB25	JMK325 B7476□JMHP	6.3	X7R	47 μ	±10, ±20	10	150	2.5±0.20	

▶ This catalog contains the typical specification only due to the limitation of space. When you consider the purchase of our products, please check our specification.
For details of each product (characteristics graph, reliability information, precautions for use, and so on), see our Web site (<http://www.ty-top.com/>).

Multilayer Ceramic Capacitors

PACKAGING

① Minimum Quantity

● Taped package

Type			Thickness		Standard Quantity [pcs]	
Code	JIS(mm)	EIA(inch)	[mm]	Code	Paper tape	Embossed tape
02	0201	008004	0.125	1	—	50000
04	0402	01005	0.2	2	—	40000
06	0603	0201	0.3	3	15000	—
1L	1005	0402	0.13	H	—	20000
			0.18	E	—	15000
			0.2	2	20000	—
			0.3	3	15000	—
10	1005	0402	0.5	5	10000	—
	0510 ※	0204	0.3	3	10000	—
16	1608	0603	0.45	K	4000	—
			0.7	7		
			0.8	8		
			0.8	8	3000 (Soft Termination)	3000 (Soft Termination)
	0816 ※	0306	0.5	5	—	4000
21	2012	0805	0.85	9	4000	—
			1.25	G	—	3000
	1.25	G	—	2000 (Soft Termination)		
1220 ※	0508	0.85	9	4000	—	
31	3216	1206	0.85	9	4000	—
			1.15	Q	—	3000
			1.6	L	—	2000
32	3225	1210	0.85	9	—	2000
			1.15	Q		
			1.9	N		
			2.0 max	Y		
			2.5	M	—	500(T), 1000(P)
45	4532	1812	2.0 max	Y	—	1000
			2.5	M	—	500

注: ※LW Reverse type (MSRL, MCRL, MBRL, MLRL, MMRL)

② Taping material

※ No bottom tape for pressed carrier tape

- Card board carrier tape
- Embossed tape

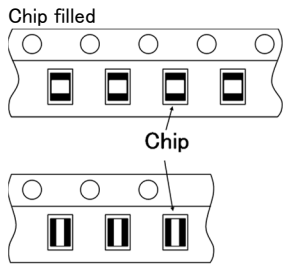
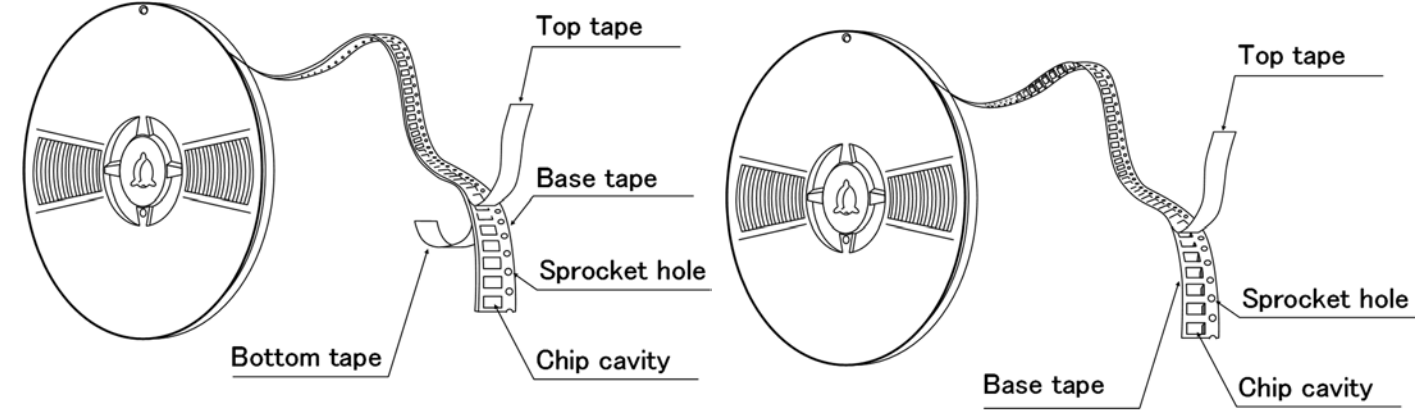

※ LW Reverse type.

③ Representative taping dimensions

● Paper Tape (8mm wide)

● Pressed carrier tape (2mm pitch)

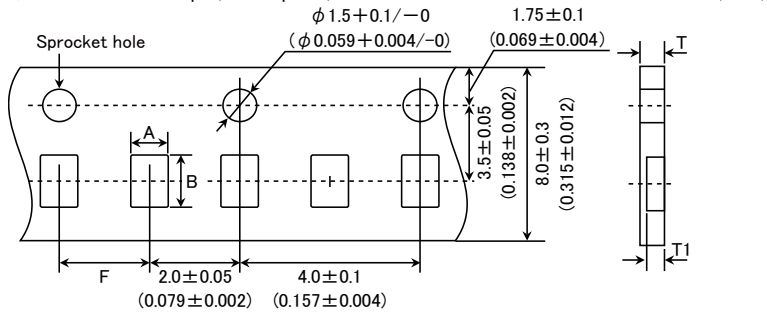

Type(EIA)	Chip Cavity		Insertion Pitch F	Tape Thickness	
	A	B		T	T1
0603 (0201)	0.37	0.67	2.0 ± 0.05	0.45max.	0.42max.
0510 (0204) ※	0.65	1.15		0.4max.	0.3max.
1005 (0402) (*1 2)				0.45max.	0.42max.
1005 (0402) (*1 3)					

Note *1 Thickness, 2:0.2mm, 3:0.3mm. ※ LW Reverse type.

Unit: mm

● Punched carrier tape (2mm pitch)

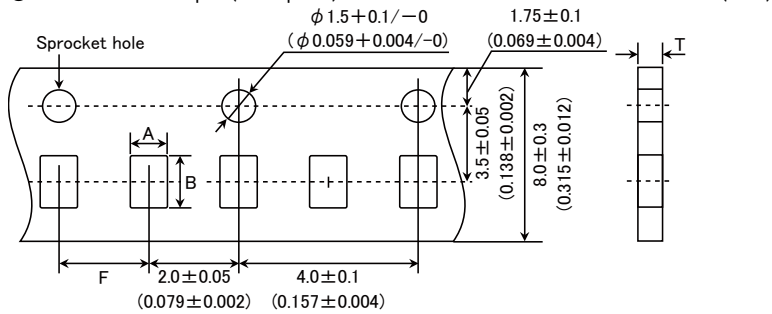

Type(EIA)	Chip Cavity		Insertion Pitch F	Tape Thickness
	A	B		T
1005 (0402)	0.65	1.15	2.0 ± 0.05	0.8max.

Unit: mm

▶ This catalog contains the typical specification only due to the limitation of space. When you consider the purchase of our products, please check our specification. For details of each product (characteristics graph, reliability information, precautions for use, and so on), see our Web site (<http://www.ty-top.com/>).

● Punched carrier tape (4mm pitch)

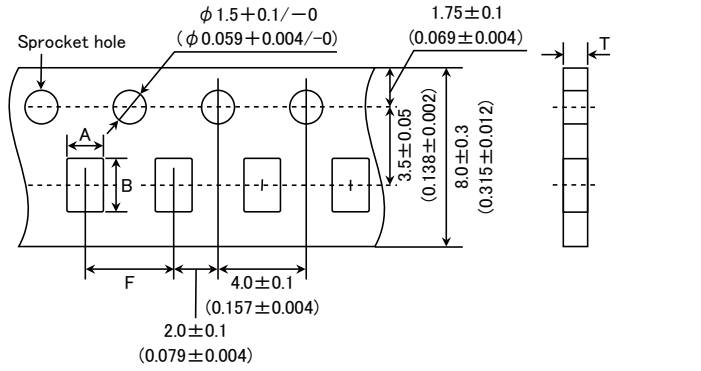

Type(EIA)	Chip Cavity		Insertion Pitch F	Tape Thickness	
	A	B		K	T
1608 (0603)	1.0	1.8	4.0±0.1	1.1max.	1.1max.
0816 (0306) ※					
2012 (0805)					
1220 (0508) ※	1.65	2.4	4.0±0.1	1.1max.	1.1max.
3216 (1206)	2.0	3.6			

Note: Taping size might be different depending on the size of the product. ※ LW Reverse type.

Unit: mm

● Embossed tape (4mm wide)

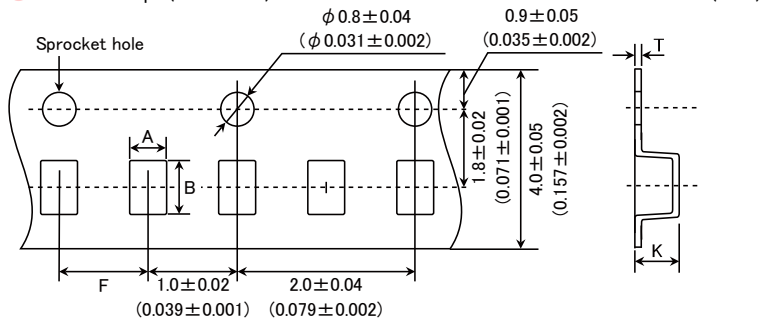

Type(EIA)	Chip Cavity		Insertion Pitch F	Tape Thickness	
	A	B		K	T
0201 (008004)	0.135	0.27	1.0±0.02	0.5max.	0.25max.
0402 (01005)	0.23	0.43			

Unit: mm

● Embossed tape (8mm wide)

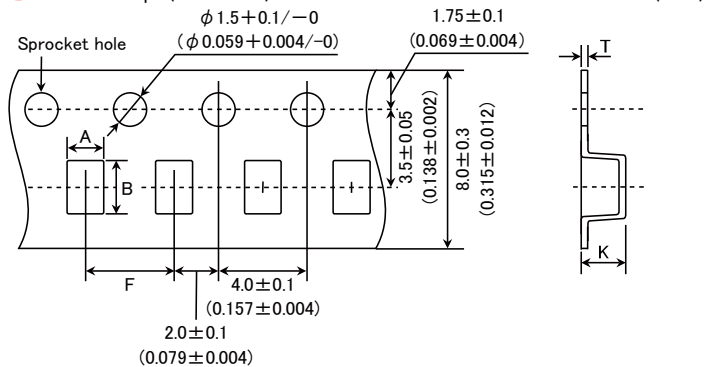

Type(EIA)	Chip Cavity		Insertion Pitch F	Tape Thickness	
	A	B		K	T
1005 (0402)	0.6	1.1	2.0±0.1	0.6max	0.2±0.1
0816 (0306) ※	1.0	1.8	4.0±0.1	1.3max.	0.25±0.1
2012 (0805)	1.65	2.4			
3216 (1206)	2.0	3.6		3.4max.	0.6max.
3225 (1210)	2.8	3.6			

Note: ※ LW Reverse type.

Unit: mm

► This catalog contains the typical specification only due to the limitation of space. When you consider the purchase of our products, please check our specification. For details of each product (characteristics graph, reliability information, precautions for use, and so on), see our Web site (<http://www.ty-top.com/>).

● Embossed tape (12mm wide) Unit: mm (inch)

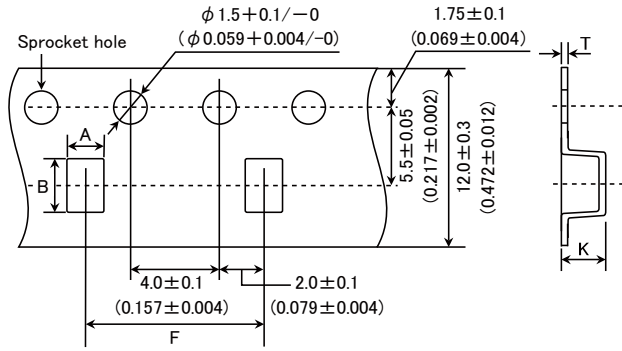

Type(EIA)	Chip Cavity		Insertion Pitch	Tape Thickness	
	A	B		K	T
3225 (1210)	3.1	4.0	8.0 ± 0.1	4.0max.	0.6max.
4532 (1812)	3.7	4.9	8.0 ± 0.1	4.0max.	0.6max.

Unit: mm

④ Trailer and Leader

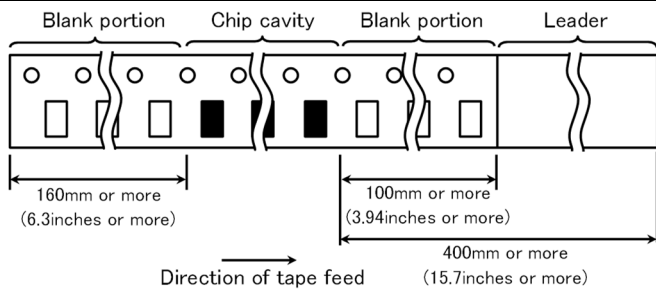

⑤ Reel size

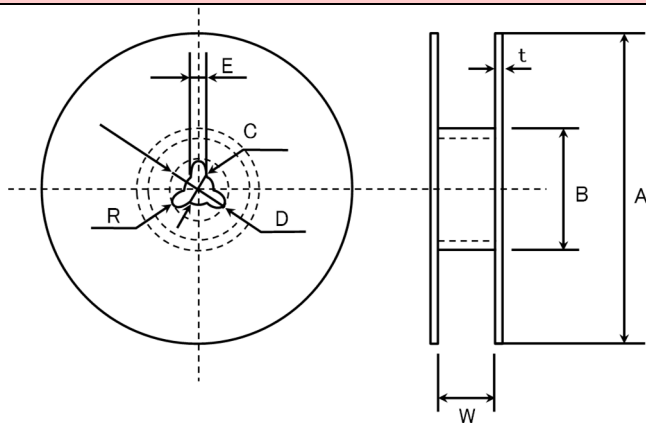

A	B	C	D	E	R
$\phi 178 \pm 2.0$	$\phi 50 \text{min.}$	$\phi 13.0 \pm 0.2$	$\phi 21.0 \pm 0.8$	2.0 ± 0.5	1.0

	T	W
4mm wide tape	1.5max.	5 ± 1.0
8mm wide tape	2.5max.	10 ± 1.5
12mm wide tape	2.5max.	14 ± 1.5

Unit: mm

⑥ Top Tape Strength

The top tape requires a peel-off force of 0.1 to 0.7N in the direction of the arrow as illustrated below.

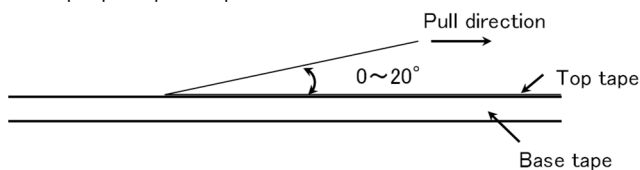

▶ This catalog contains the typical specification only due to the limitation of space. When you consider the purchase of our products, please check our specification. For details of each product (characteristics graph, reliability information, precautions for use, and so on), see our Web site (<http://www.ty-top.com/>).

Multilayer Ceramic Capacitors for Telecommunications Infrastructure and Industrial Equipment

Multilayer Ceramic Capacitors for Medical Devices classified as GHTF Class C (Japan Class III)

RELIABILITY DATA

1. Operating Temperature Range

Specified Value	Temperature Compensating(Class1)	-55 to +125°C		
	High Permittivity (Class2)		Specification	Temperature Range
		B5	X5R	-55 to +85°C
		B7	X7R	-55 to +125°C
		C6	X6S	-55 to +105°C
		C7	X7S	-55 to +125°C
D7	X7T	-55 to +125°C		

2. Storage Conditions

Specified Value	Temperature Compensating(Class1)	-55 to +125°C		
	High Permittivity (Class2)		Specification	Temperature Range
		B5	X5R	-55 to +85°C
		B7	X7R	-55 to +125°C
		C6	X6S	-55 to +105°C
		C7	X7S	-55 to +125°C
D7	X7T	-55 to +125°C		

3. Rated Voltage

Specified Value	Temperature Compensating(Class1)	50VDC, 25VDC
	High Permittivity (Class2)	50VDC, 35VDC, 25VDC, 16VDC, 10VDC, 6.3VDC, 4VDC

4. Withstanding Voltage (Between terminals)

Specified Value	Temperature Compensating(Class1)	No breakdown or damage	
	High Permittivity (Class2)		
Test Methods and Remarks		Class 1	Class 2
	Applied voltage	Rated volta × 3	Rated voltage × 2.5
	Duration	1 to 5 sec.	
	Charge/discharge current	50mA max.	

5. Insulation Resistance

Specified Value	Temperature Compensating(Class1)	10000 MΩ min.
	High Permittivity (Class2) Note 1	$C \leq 0.047 \mu F$: 10000 MΩ min. $C > 0.047 \mu F$: $500M\Omega \cdot \mu F$ (C:Nominal capacitance)
Test Methods and Remarks	Applied voltage	: Rated voltage
	Duration	: 60±5 sec.
	Charge/discharge current	: 50mA max.

6. Capacitance (Tolerance)

Specified Value	Temperature Compensating(Class1)	$C \leq 5pF$: ±0.25pF $5pF < C \leq 10pF$: ±0.5pF $C > 10pF$: ±5% (C:Nominal capacitance)		
	High Permittivity (Class2)	±10% or ±20%		
Test Methods and Remarks		Class 1	Class 2	
	Preconditioning	None	$C \leq 10 \mu F$	$C > 10 \mu F$
	Measuring frequency	1MHz±10%	Thermal treatment (at 150°C for 1hr) Note 2	
	Measuring voltage Note 1	0.5 to 5Vrms	1±0.2Vrms	120±10Hz
	Bias application	None		

► This catalog contains the typical specification only due to the limitation of space. When you consider the purchase of our products, please check our specification. For details of each product (characteristics graph, reliability information, precautions for use, and so on), see our Web site (<http://www.ty-top.com/>).

7. Q or Dissipation Factor

Specified Value	Temperature Compensating(Class1)	C < 30pF : Q ≥ 400 + 20C C ≥ 30pF : Q ≥ 1000 (C: Nominal capacitance)		
	High Permittivity (Class2) Note 1	2.5% max.		
Test Methods and Remarks		Class 1	Class 2	
			C ≤ 10 μF C > 10 μF	
	Preconditioning	None	Thermal treatment (at 150°C for 1hr) Note 2	
	Measuring frequency	1MHz ± 10%	1kHz ± 10%	120 ± 10Hz
	Measuring voltage Note 1	0.5 to 5Vrms	1 ± 0.2Vrms	0.5 ± 0.1Vrms
Bias application	None			

8. Temperature Characteristic (Without voltage application)

Specified Value	Temperature Compensating(Class1)	Temperature Characteristic [ppm/°C]		Tolerance [ppm/°C]	
		C□: 0	CG, CH, CJ, CK	G : ±30	H : ±60
High Permittivity (Class2)		Specification	Capacitance change	Reference temperature	Temperature Range
	B5	X5R	±15%	25°C	-55 to +85°C
	B7	X7R	±15%	25°C	-55 to +125°C
	C6	X6S	±22%	25°C	-55 to +105°C
	C7	X7S	±22%	25°C	-55 to +125°C
	D7	X7T	+22/-33%	25°C	-55 to +125°C

Class 1 : Capacitance at 20°C and 85°C shall be measured in thermal equilibrium, and the temperature characteristic shall be calculated from the following equation.

$$\frac{(C_{85} - C_{20})}{C_{20} \times \Delta T} \times 10^6 (\text{ppm}/^\circ\text{C}) \quad \Delta T = 65$$

Class 2 : Capacitance at each step shall be measured in thermal equilibrium, and the temperature characteristic shall be calculated from the following equation.

Step	Temperature
1	Minimum operating temperature
2	25°C
3	Maximum operating temperature

$$\frac{(C - C_2)}{C_2} \times 100 (\%)$$

C : Capacitance in Step 1 or Step 3
C2 : Capacitance in Step 2
※Measuring Frequency, Measuring Voltage: Refer to detailed specification

9. Deflection

Specified Value	Temperature Compensating(Class1)	Appearance : No abnormality Capacitance change : Within ±5% or ±0.5 pF, whichever is larger.
	High Permittivity (Class2)	Appearance : No abnormality Capacitance change : Within ±12.5%

Test Methods and Remarks	Multilayer Ceramic Capacitors	
	0603, ※11005 Type	The other types
	Glass epoxy-resin substrate	
	Board	0.8mm 1.6mm
	Warp	1mm (Soft Termination type:3mm)
Duration	10 sec.	

※1: 1005 Type thickness, ,3: 0.3mm.

(Unit: mm)
Capacitance measurement shall be conducted with the board bent

▶ This catalog contains the typical specification only due to the limitation of space. When you consider the purchase of our products, please check our specification. For details of each product (characteristics graph, reliability information, precautions for use, and so on), see our Web site (<http://www.ty-top.com/>).

10. Adhesive Strength of Terminal Electrodes

Specified Value	Temperature Compensating(Class1)	No terminal separation or its indication.	
	High Permittivity (Class2)		
Test Methods and Remarks		0603 Type	1005 Type or more
	Applied force	2N	5N
	Duration	10±1 sec.	30±5 sec. (Soft Termination type: 10±1 sec.)

11. Vibration

Specified Value	Temperature Compensating(Class1)	Initial performance shall be satisfied.
	High Permittivity (Class2)	
Test Methods and Remarks	Preconditioning	: Thermal treatment (at 150°C for 1hr) Note2 (Only High permittivity)
	Frequency range	: 10 to 55 Hz
	Overall amplitude	: 1.5 mm
	Sweeping method	: 10 to 55 to 10 Hz for 1 min
		Two hours each in X, Y, Z directions: 6 hrs in total

12. Solderability

Specified Value	Temperature Compensating(Class1)	At least 95% of terminal electrode is covered by new solder.	
	High Permittivity (Class2)		
Test Methods and Remarks		Eutectic solder	Lead-free solder
	Solder type	H60A or H63A	Sn-3.0Ag-0.5Cu
	Solder temperature	230±5°C	245±3°C
	Duration	4±1 sec.	

13. Resistance to Soldering

Specified Value	Temperature Compensating(Class1)	Appearance	: No abnormality	
		Capacitance change	: Within ±2.5% or ±0.25pF, whichever is larger.	
Specified Value	High Permittivity (Class2) Note 1	Q	: Initial value	
		Insulation resistance	: Initial value	
Specified Value	High Permittivity (Class2) Note 1	Withstanding voltage (between terminals)	: No abnormality	
		Appearance	: No abnormality	
Specified Value	High Permittivity (Class2) Note 1	Capacitance change	: Within ±7.5%	
		Dissipation factor	: Initial value	
Specified Value	High Permittivity (Class2) Note 1	Insulation resistance	: Initial value	
		Withstanding voltage (between terminals)	: No abnormality	
Test Methods and Remarks		Class 1		
		0603 Type	1005 Type	
	Preconditioning	None		
	Preheating	150°C, 1 to 2 min.	80 to 100°C, 2 to 5 min. 150 to 200°C, 2 to 5 min.	
	Solder temp.	270±5°C		
	Duration	3±0.5 sec.		
	Recovery	24±2hrs (Standard condition) Note 5		
		Class 2		
		0603 Type	1005, 1608, 2012 Type	3216, 3225 Type
	Preconditioning	Thermal treatment (at 150°C for 1 hr) Note 2		
	Preheating	150°C, 1 to 2 min.	80 to 100°C, 2 to 5 min. 150 to 200°C, 2 to 5 min.	80 to 100°C, 5 to 10 min. 150 to 200°C, 5 to 10 min.
	Solder temp.	270±5°C		
	Duration	3±0.5 sec.		
	Recovery	24±2 hrs (Standard condition) Note 5		

► This catalog contains the typical specification only due to the limitation of space. When you consider the purchase of our products, please check our specification. For details of each product (characteristics graph, reliability information, precautions for use, and so on), see our Web site (<http://www.ty-top.com/>).

14. Temperature Cycle (Thermal Shock)

Specified Value	Temperature Compensating(Class1)	Appearance : No abnormality Capacitance change : Within $\pm 2.5\%$ or $\pm 0.25\text{pF}$, whichever is larger. Q : Initial value Insulation resistance : Initial value Withstanding voltage (between terminals) : No abnormality		
	High Permittivity (Class2) Note 1	Appearance : No abnormality Capacitance change : Within $\pm 7.5\%$ Dissipation factor : Initial value Insulation resistance : Initial value Withstanding voltage (between terminals) : No abnormality		
Test Methods and Remarks	Class 1	Class 2		
	Preconditioning	None	Thermal treatment (at 150°C for 1 hr) Note 2	
	1 cycle	Step	Temperature (°C)	Time (min.)
		1	Minimum operating temperature	30±3
		2	Normal temperature	2 to 3
3		Maximum operating temperature	30±3	
4	Normal temperature	2 to 3	2 to 3	
Number of cycles	50 times			
Recovery	24±2hrs (Standard condition) Note 5	24±2 hrs (Standard condition) Note 5		

15. Humidity (Steady State)

Specified Value	Temperature Compensating(Class1)	Appearance : No abnormality Capacitance change : Within $\pm 5\%$ or $\pm 0.5\text{pF}$, whichever is larger. Q : $C < 10\text{pF} : Q \geq 200 + 10C$ $10 \leq C < 30\text{pF} : Q \geq 275 + 2.5C$ $C \geq 30\text{pF} : Q \geq 350$ (C:Nominal capacitance) Insulation resistance : 1000 M Ω min.
	High Permittivity (Class2) Note 1	Appearance : No abnormality Capacitance change : Within $\pm 12.5\%$ Dissipation factor : 5.0% max. Insulation resistance : 50 M Ω μ F or 1000 M Ω whichever is smaller.
Test Methods and Remarks	Preconditioning : Thermal treatment (at 150°C for 1 hr) Note 2 (Only High permittivity) Temperature : 40±2°C Humidity : 90 to 95%RH Duration : 500+24/-0 hrs Recovery : 24±2 hrs (Standard condition) Note 1,5	

16. Humidity Loading

Specified Value	Temperature Compensating(Class1)	Appearance : No abnormality Capacitance change : Within $\pm 7.5\%$ or $\pm 0.75\text{pF}$, whichever is larger. Q : $C < 30\text{pF} : Q \geq 100 + 10C/3$ $C \geq 30\text{pF} : Q \geq 200$ (C:Nominal capacitance) Insulation resistance : 500 M Ω min.
	High Permittivity (Class2) Note 1	Appearance : No abnormality Capacitance change : Within $\pm 12.5\%$ Dissipation factor : 5.0% max. Insulation resistance : 25 M Ω μ F or 500 M Ω , whichever is smaller.
Test Methods and Remarks	Preconditioning : Voltage treatment (Rated voltage are applied for 1 hour at 40°C) Note 1,3 (Only High permittivity) Temperature : 60±2°C Humidity : 90 to 95%RH Duration : 500+24/-0 hrs Applied voltage : Rated voltage Charge/discharge current : 50mA max. Recovery : 24±2 hrs (Standard condition) Note 1,5	

► This catalog contains the typical specification only due to the limitation of space. When you consider the purchase of our products, please check our specification. For details of each product (characteristics graph, reliability information, precautions for use, and so on), see our Web site (<http://www.ty-top.com/>).

17. High Temperature Loading

Specified Value	Temperature Compensating(Class1)	Appearance : No abnormality Capacitance change : Within $\pm 3\%$ or $\pm 0.3\text{pF}$, whichever is larger. Q : $C < 10\text{pF}$: $Q \geq 200 + 10C$ $10 \leq C < 30\text{pF}$: $Q \geq 275 + 2.5C$ $C \geq 30\text{pF}$: $Q \geq 350$ (C: Nominal capacitance) Insulation resistance : 1000 M Ω min.
	High Permittivity (Class2) Note 1	Appearance : No abnormality Capacitance change : Within $\pm 12.5\%$ Dissipation factor : 5.0% max. Insulation resistance : 50 M Ω μF or 1000 M Ω , whichever is smaller.
Test Methods and Remarks	Preconditioning : Voltage treatment (Twice the rated voltage shall be applied for 1 hour at 85°C, 105°C or 125°C) Note 1,3,4 (Only High permittivity) Temperature : Maximum operating temperature Duration : 1000+24/-0 hrs Applied voltage : Rated voltage $\times 2$ Note 4 Charge/discharge current : 50mA max. Recovery : 24 \pm 2 hrs (Standard condition) Note 1,5	

Note 1 The figures indicate typical specifications. Please refer to individual specifications in detail.

Note 2 Thermal treatment : Initial value shall be measured after test sample is heat-treated at 150+0/-10°C for an hour and kept at room temperature for 24 \pm 2hours.

Note 3 Voltage treatment : Initial value shall be measured after test sample is voltage-treated for an hour at both the temperature and voltage specified in the test conditions, and kept at room temperature for 24 \pm 2hours.

Note 4 150% of rated voltage is applicable to some items. Please refer to their specifications for further information.

Note 5 Standard condition: Temperature: 5 to 35°C, Relative humidity: 45 to 85 % RH, Air pressure: 86 to 106kPa When there are questions concerning measurement results, in order to provide correlation data, the test shall be conducted under the following condition.

Temperature: 20 \pm 2°C, Relative humidity: 60 to 70 % RH, Air pressure: 86 to 106kPa Unless otherwise specified, all the tests are conducted under the "standard condition".

Multilayer Ceramic Capacitors

PRECAUTIONS

1. Circuit Design

- Precautions**
- ◆ Verification of operating environment, electrical rating and performance
 1. A malfunction of equipment in fields such as medical, aerospace, nuclear control, etc. may cause serious harm to human life or have severe social ramifications. Therefore, any capacitors to be used in such equipment may require higher safety and reliability, and shall be clearly differentiated from them used in general purpose applications.
 - ◆ Operating Voltage (Verification of Rated voltage)
 1. The operating voltage for capacitors must always be their rated voltage or less.
 - If an AC voltage is loaded on a DC voltage, the sum of the two peak voltages shall be the rated voltage or less.
 - For a circuit where an AC or a pulse voltage may be used, the sum of their peak voltages shall also be the rated voltage or less.
 2. Even if an applied voltage is the rated voltage or less reliability of capacitors may be deteriorated in case that either a high frequency AC voltage or a pulse voltage having rapid rise time is used in a circuit.

2. PCB Design

- Precautions**
- ◆ Pattern configurations (Design of Land-patterns)
 1. When capacitors are mounted on PCBs, the amount of solder used (size of fillet) can directly affect the capacitor performance. Therefore, the following items must be carefully considered in the design of land patterns:
 - (1) Excessive solder applied can cause mechanical stresses which lead to chip breaking or cracking. Therefore, please consider appropriate land-patterns for proper amount of solder.
 - (2) When more than one component are jointly soldered onto the same land, each component's soldering point shall be separated by solder-resist.
 - ◆ Pattern configurations (Capacitor layout on PCBs)

After capacitors are mounted on boards, they can be subjected to mechanical stresses in subsequent manufacturing processes (PCB cutting, board inspection, mounting of additional parts, assembly into the chassis, wave soldering of the boards, etc.). For this reason, land pattern configurations and positions of capacitors shall be carefully considered to minimize stresses.

Technical considerations

- ◆ Pattern configurations (Design of Land-patterns)

The following diagrams and tables show some examples of recommended land patterns to prevent excessive solder amounts.

(1) Recommended land dimensions for typical chip capacitors

 - Multilayer Ceramic Capacitors : Recommended land dimensions (unit: mm)

Wave-soldering

Type	1608	2012	3216	3225	
Size	L	1.6	2.0	3.2	3.2
	W	0.8	1.25	1.6	2.5
A	0.8 to 1.0	1.0 to 1.4	1.8 to 2.5	1.8 to 2.5	
B	0.5 to 0.8	0.8 to 1.5	0.8 to 1.7	0.8 to 1.7	
C	0.6 to 0.8	0.9 to 1.2	1.2 to 1.6	1.8 to 2.5	

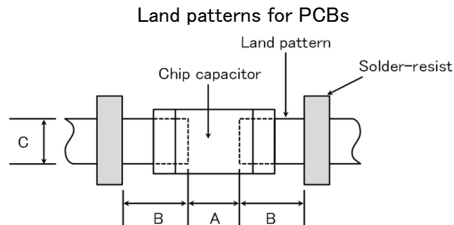

Reflow-soldering

Type	0201	0402	0603	1005	1608	2012	3216	3225	4532
Size	L	0.25	0.4	0.6	1.0	1.6	2.0	3.2	4.5
	W	0.125	0.2	0.3	0.5	0.8	1.25	1.6	3.2
A	0.095~0.135	0.15~0.25	0.20~0.30	0.45~0.55	0.6~0.8	0.8~1.2	1.8~2.5	1.8~2.5	2.5~3.5
B	0.085~0.125	0.10~0.20	0.20~0.30	0.40~0.50	0.6~0.8	0.8~1.2	1.0~1.5	1.0~1.5	1.5~1.8
C	0.110~0.150	0.15~0.30	0.25~0.40	0.45~0.55	0.6~0.8	0.9~1.6	1.2~2.0	1.8~3.2	2.3~3.5

Note: Recommended land size might be different according to the allowance of the size of the product.

 - LWDC: Recommended land dimensions for reflow-soldering (unit: mm)

Type	0510	0816	1220	
Size	L	0.52	0.8	1.25
	W	1.0	1.6	2.0
A	0.18~0.22	0.25~0.3	0.5~0.7	
B	0.2~0.25	0.3~0.4	0.4~0.5	
C	0.9~1.1	1.5~1.7	1.9~2.1	

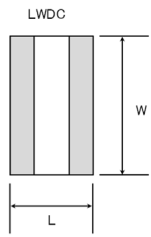

▶ This catalog contains the typical specification only due to the limitation of space. When you consider the purchase of our products, please check our specification. For details of each product (characteristics graph, reliability information, precautions for use, and so on), see our Web site (<http://www.ty-top.com/>).

(2) Examples of good and bad solder application

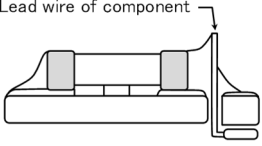
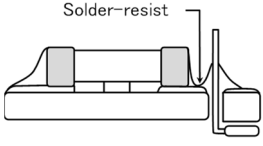
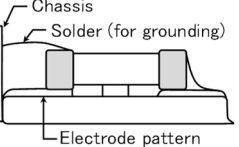
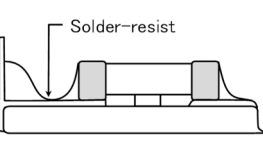
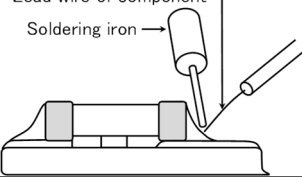
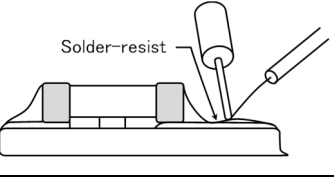
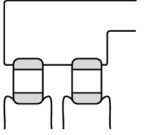
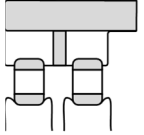
Item	Not recommended	Recommended
Mixed mounting of SMD and leaded components		
Component placement close to the chassis		
Hand-soldering of leaded components near mounted components		
Horizontal component placement		

◆ Pattern configurations (Capacitor layout on PCBs)

1-1. The following is examples of good and bad capacitor layouts ; capacitors shall be located to minimize any possible mechanical stresses from board warp or deflection.

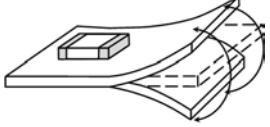
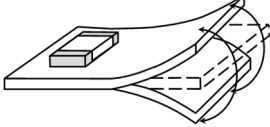
Items	Not recommended	Recommended
Deflection of board		 Place the product at a right angle to the direction of the anticipated mechanical stress.

1-2. The amount of mechanical stresses given will vary depending on capacitor layout. Please refer to diagram below.

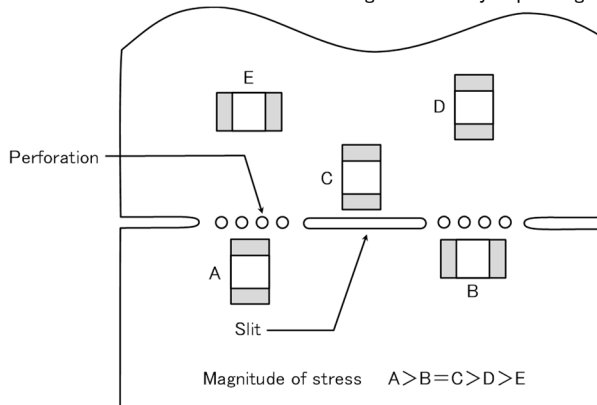

1-3. When PCB is split, the amount of mechanical stress on the capacitors can vary according to the method used. The following methods are listed in order from least stressful to most stressful: push-back, slit, V-grooving, and perforation. Thus, please consider the PCB, split methods as well as chip location.

3. Mounting

Precautions

◆ Adjustment of mounting machine

- When capacitors are mounted on PCB, excessive impact load shall not be imposed on them.
- Maintenance and inspection of mounting machines shall be conducted periodically.

◆ Selection of Adhesives

- When chips are attached on PCBs with adhesives prior to soldering, it may cause capacitor characteristics degradation unless the following factors are appropriately checked : size of land patterns, type of adhesive, amount applied, hardening temperature and hardening period. Therefore, please contact us for further information.

◆ Adjustment of mounting machine

1. When the bottom dead center of a pick-up nozzle is too low, excessive force is imposed on capacitors and causes damages. To avoid this, the following points shall be considerable.
 - (1) The bottom dead center of the pick-up nozzle shall be adjusted to the surface level of PCB without the board deflection.
 - (2) The pressure of nozzle shall be adjusted between 1 and 3 N static loads.
 - (3) To reduce the amount of deflection of the board caused by impact of the pick-up nozzle, supporting pins or back-up pins shall be used on the other side of the PCB. The following diagrams show some typical examples of good and bad pick-up nozzle placement:

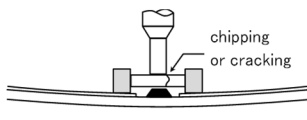
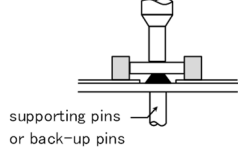
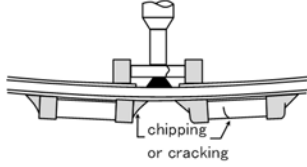
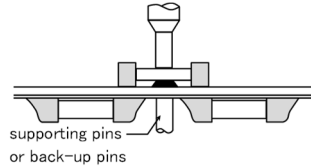
Item	Improper method	Proper method
Single-sided mounting		
Double-sided mounting		

Technical considerations

2. As the alignment pin is worn out, adjustment of the nozzle height can cause chipping or cracking of capacitors because of mechanical impact on the capacitors. To avoid this, the monitoring of the width between the alignment pins in the stopped position, maintenance, check and replacement of the pin shall be conducted periodically.

◆ Selection of Adhesives

Some adhesives may cause IR deterioration. The different shrinkage percentage of between the adhesive and the capacitors may result in stresses on the capacitors and lead to cracking. Moreover, too little or too much adhesive applied to the board may adversely affect components. Therefore, the following precautions shall be noted in the application of adhesives.

- (1) Required adhesive characteristics
 - a. The adhesive shall be strong enough to hold parts on the board during the mounting & solder process.
 - b. The adhesive shall have sufficient strength at high temperatures.
 - c. The adhesive shall have good coating and thickness consistency.
 - d. The adhesive shall be used during its prescribed shelf life.
 - e. The adhesive shall harden rapidly.
 - f. The adhesive shall have corrosion resistance.
 - g. The adhesive shall have excellent insulation characteristics.
 - h. The adhesive shall have no emission of toxic gasses and no effect on the human body.
- (2) The recommended amount of adhesives is as follows:

[Recommended condition]

Figure	2012/3216 case sizes as examples
a	0.3mm min
b	100 to 120 μm
c	Adhesives shall not contact land

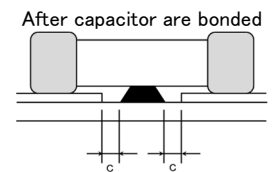
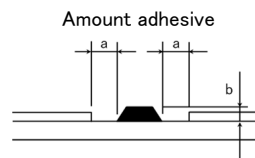

4. Soldering

◆ Selection of Flux

Since flux may have a significant effect on the performance of capacitors, it is necessary to verify the following conditions prior to use;

- (1) Flux used shall be less than or equal to 0.1 wt% (in Cl equivalent) of halogenated content. Flux having a strong acidity content shall not be applied.
- (2) When shall capacitors are soldered on boards, the amount of flux applied shall be controlled at the optimum level.
- (3) When water-soluble flux is used, special care shall be taken to properly clean the boards.

Precautions

◆ Soldering

Temperature, time, amount of solder, etc. shall be set in accordance with their recommended conditions.

Sn-Zn solder paste can adversely affect MLCC reliability.

Please contact us prior to usage of Sn-Zn solder.

◆ Selection of Flux

- 1-1. When too much halogenated substance (Chlorine, etc.) content is used to activate flux, or highly acidic flux is used, it may lead to corrosion of terminal electrodes or degradation of insulation resistance on the surfaces of the capacitors.
- 1-2. Flux is used to increase solderability in wave soldering. However if too much flux is applied, a large amount of flux gas may be emitted and may adversely affect the solderability. To minimize the amount of flux applied, it is recommended to use a flux-bubbling system.
- 1-3. Since the residue of water-soluble flux is easily dissolved in moisture in the air, the residues on the surfaces of capacitors in high humidity conditions may cause a degradation of insulation resistance and reliability of the capacitors. Therefore, the cleaning methods

Technical considerations

▶ This catalog contains the typical specification only due to the limitation of space. When you consider the purchase of our products, please check our specification. For details of each product (characteristics graph, reliability information, precautions for use, and so on), see our Web site (<http://www.ty-top.com/>).

and the capability of the machines used shall also be considered carefully when water-soluble flux is used.

◆Soldering

- Ceramic chip capacitors are susceptible to thermal shock when exposed to rapid or concentrated heating or rapid cooling.
- Therefore, the soldering must be conducted with great care so as to prevent malfunction of the components due to excessive thermal shock.
- Preheating : Capacitors shall be preheated sufficiently, and the temperature difference between the capacitors and solder shall be within 130°C.
- Cooling : The temperature difference between the capacitors and cleaning process shall not be greater than 100°C.

[Reflow soldering]

【Recommended conditions for eutectic soldering】

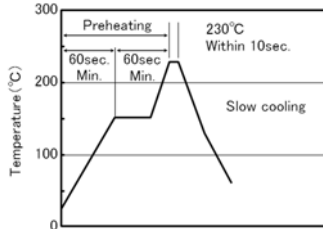

【Recommended condition for Pb-free soldering】

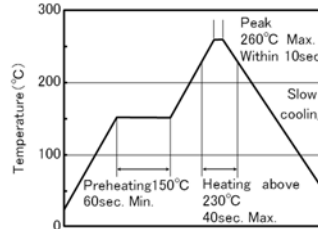

Caution

- ①The ideal condition is to have solder mass (fillet) controlled to 1/2 to 1/3 of the thickness of a capacitor.
- ②Because excessive dwell times can adversely affect solderability, soldering duration shall be kept as close to recommended times as possible. soldering for 2 times.

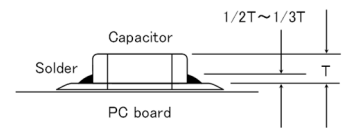

[Wave soldering]

【Recommended conditions for eutectic soldering】

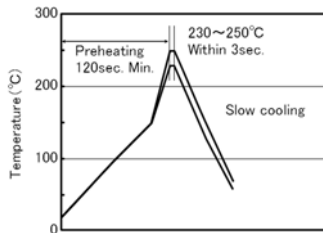

【Recommended condition for Pb-free soldering】

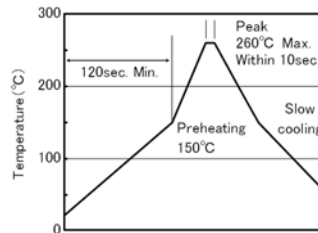

Caution

- ①Wave soldering must not be applied to capacitors designated as for reflow soldering only. soldering for 1 times.

[Hand soldering]

【Recommended conditions for eutectic soldering】

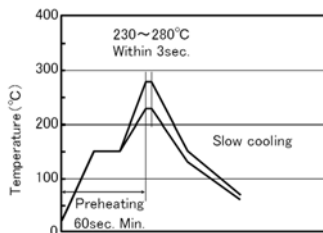

【Recommended condition for Pb-free soldering】

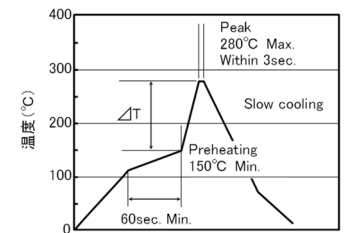
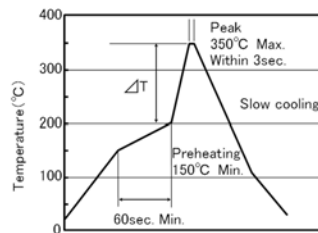

	ΔT
3216type or less	$\Delta T \leq 150^\circ\text{C}$

	ΔT
3225type or more	$\Delta T \leq 130^\circ\text{C}$

Caution

- ①Use a 50W soldering iron with a maximum tip diameter of 1.0 mm.
- ②The soldering iron shall not directly touch capacitors. soldering for 1 times.

5. Cleaning	
Precautions	<p>◆Cleaning conditions</p> <ol style="list-style-type: none"> When PCBs are cleaned after capacitors mounting, please select the appropriate cleaning solution in accordance with the intended use of the cleaning. (e.g. to remove soldering flux or other materials from the production process.) Cleaning condition shall be determined after it is verified by using actual cleaning machine that the cleaning process does not affect capacitor's characteristics.
Technical considerations	<ol style="list-style-type: none"> The use of inappropriate cleaning solutions can cause foreign substances such as flux residue to adhere to capacitors or deteriorate their outer coating, resulting in a degradation of the capacitor's electrical properties (especially insulation resistance). Inappropriate cleaning conditions (insufficient or excessive cleaning) may adversely affect the performance of the capacitors. In the case of ultrasonic cleaning, too much power output can cause excessive vibration of PCBs which may lead to the cracking of capacitors or the soldered portion, or decrease the terminal electrodes' strength. Therefore, the following conditions shall be carefully checked: Ultrasonic output : 20 W/l or less Ultrasonic frequency : 40 kHz or less Ultrasonic washing period : 5 min. or less

6. Resin coating and mold	
Precautions	<ol style="list-style-type: none"> With some type of resins, decomposition gas or chemical reaction vapor may remain inside the resin during the hardening period or while left under normal storage conditions resulting in the deterioration of the capacitor's performance. When a resin's hardening temperature is higher than capacitor's operating temperature, the stresses generated by the excessive heat may lead to damage or destruction of capacitors. The use of such resins, molding materials etc. is not recommended.

7. Handling	
Precautions	<p>◆Splitting of PCB</p> <ol style="list-style-type: none"> When PCBs are split after components mounting, care shall be taken so as not to give any stresses of deflection or twisting to the board. Board separation shall not be done manually, but by using the appropriate devices. <p>◆Mechanical considerations</p> <p>Be careful not to subject capacitors to excessive mechanical shocks.</p> <ol style="list-style-type: none"> If ceramic capacitors are dropped onto a floor or a hard surface, they shall not be used. Please be careful that the mounted components do not come in contact with or bump against other boards or components.

8. Storage conditions	
Precautions	<p>◆Storage</p> <ol style="list-style-type: none"> To maintain the solderability of terminal electrodes and to keep packaging materials in good condition, care must be taken to control temperature and humidity in the storage area. Humidity should especially be kept as low as possible. <ul style="list-style-type: none"> Recommended conditions Ambient temperature : Below 30°C Humidity : Below 70% RH The ambient temperature must be kept below 40°C. Even under ideal storage conditions, solderability of capacitor is deteriorated as time passes, so capacitors shall be used within 6 months from the time of delivery. <ul style="list-style-type: none"> Ceramic chip capacitors shall be kept where no chlorine or sulfur exists in the air. The capacitance values of high dielectric constant capacitors will gradually decrease with the passage of time, so care shall be taken to design circuits. Even if capacitance value decreases as time passes, it will get back to the initial value by a heat treatment at 150°C for 1hour.
Technical considerations	<p>If capacitors are stored in a high temperature and humidity environment, it might rapidly cause poor solderability due to terminal oxidation and quality loss of taping/packaging materials. For this reason, capacitors shall be used within 6 months from the time of delivery. If exceeding the above period, please check solderability before using the capacitors.</p>

※RCR-2335B (Safety Application Guide for fixed ceramic capacitors for use in electronic equipment) is published by JEITA.

Please check the guide regarding precautions for deflection test, soldering by spot heat, and so on.